

SAFETY VALVE

Model
JSV-LT12

Lift Type Safety Valve

Screwed
Spring loaded

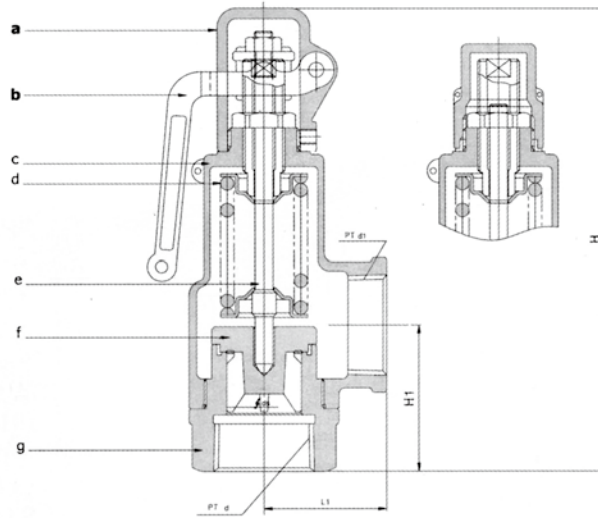
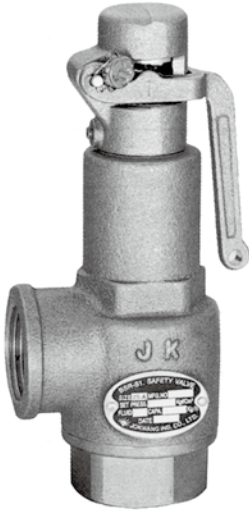

As angle type spring loaded lift safety valve for steam, air and water, JSV-LT12 is suitable for small and medium capacity applications such as small boiler or pressure vessel, and tracing equipment.

- Quickly popping reaction and correct re-seating
- Easy adjustment of set pressure and blow-down pressure

SPECIFICATIONS

Working pressure ranges : 0.35~1, 1.1~2, 2.1~4, 4.1~7, 7.1~11kgf/cm²
{0.035~0.1, 0.11~0.2, 0.21~0.4, 0.41~0.7, 0.71~1.1MPa}

Working temperature : Max. 220°C (Without lever: Max. 120°C)

Connection Inlet : female screwed
Outlet : female screwed

Hydraulic pressure test : 15kgf/cm²{1.5MPa}

Cap types available

- With lever : for periodical check in mainly steam and/or air service
- Without lever : when air-tight is required for liquid

MATERIALS

No	Part	Material
a	Cap	Forged Brass
b	Lever	Bronze
c	Bonnet	Bronze
d	Spring	Oil Tempered Alloy Steel
e	Stem	Stainless Steel
f	Disc	Forged Brass
g	Body	Forged Brass

DIMENSIONS

(mm)

Size	Inlet dia.	Seat opening dia.	Effective area (mm ²)	Lift	End to end		Height	End connection		Wt
					L ₁	H ₁		PTd ₁	PTd ₂	
15(1/2")	20	21	62.83	1.0	35	45	142	1/2"	3/4"	0.8
20(3/4")	20	21	62.83	1.0	35	45	144	3/4"	3/4"	1.0
25(1")	25	26	133.52	1.7	41	49	155	1"	1"	1.3
32(1 1/4")	32	33	221.17	2.2	45	58	173	1 1/4"	1 1/4"	2.0
40(1 1/2")	40	41	289.03	2.3	55	64	198	1 1/2"	1 1/2"	3.0
50(2")	50	51	393.70	2.5	70	74	220	2"	2"	5.7

Dimensions in millimetre approximately. The lift type safety valve is designed to have the control mechanism of flow capacity. The lifts (ℓ) of lift type safety valve are 1/40 to 1/15 of the seat opening diameter.

DISCHARGE CAPACITIES

for Model JSV-LT12

Calculation of flow according to KS B 6216 for steam and air
to J.K standard for water

Symbols for fluid

- I. Air (kg/h at 20°C with 10% accumulation)
- II. Saturated steam(kg/h with 3% accumulation)
- III. Water (m³/h at G=1 with 15% accumulation)

Set pressure (kgf/cm ²) {MPa}	Size(mm)	15A, 20A			25 A			32 A			40A			50A		
	Effective area(mm ²)	62.83			133.52			221.17			289.03			392.70		
	Fluid	I	II	III	I	II	III	I	II	III	I	II	III	I	II	III
0.1{0.01}		51.7	36.3	0.45	109.8	77.1	0.96	181.9	127.8	1.60	237.8	167.0	2.09	323.1	226.9	2.83
0.2{0.02}		56.6	39.1	0.64	120.4	83.0	1.36	199.4	137.6	2.26	260.6	179.8	2.95	354.1	244.3	4.01
0.3{0.03}		61.6	41.9	0.79	131.0	89.0	1.67	216.9	147.4	2.76	283.5	192.7	3.61	385.2	261.8	4.91
0.4{0.04}		66.6	44.6	0.91	141.5	94.9	1.93	234.5	157.3	3.19	306.4	205.5	4.17	416.3	279.3	5.67
0.5{0.05}		71.6	47.4	1.01	152.1	100.9	2.15	252.0	167.1	3.57	329.3	218.4	4.66	447.4	296.7	6.34
0.6{0.06}		76.5	50.2	1.11	162.7	106.8	2.36	269.5	176.9	3.91	352.2	231.2	5.11	478.5	314.2	6.94
0.7{0.07}		81.5	53.0	1.20	173.2	112.7	2.55	287.0	186.8	4.22	375.1	244.1	5.52	509.6	331.6	7.50
0.8{0.08}		86.5	55.8	1.28	183.8	118.7	2.72	304.5	196.6	4.51	398.0	256.9	5.90	540.7	349.1	8.01
0.9{0.09}		91.5	58.6	1.36	194.4	124.6	2.89	322.0	206.4	4.79	420.8	269.8	6.26	571.8	366.5	8.50
1.0{0.1}		96.4	61.4	1.43	205.0	130.5	3.05	339.5	216.2	5.05	443.7	282.6	6.59	602.9	384.0	8.96
2 {0.2}		146.2	85.4	2.03	310.7	181.6	4.31	514.7	300.8	7.14	672.6	393.1	9.33	913.8	534.1	12.67
3 {0.3}		195.9	114.2	2.48	416.4	242.7	5.28	689.8	402.1	8.74	901.4	525.4	11.42	1224.8	713.9	15.52
4 {0.4}		245.7	143.0	2.87	522.1	303.8	6.09	864.9	503.3	10.09	1130.3	657.8	13.19	1535.7	893.7	17.92
5 {0.5}		295.4	171.7	3.21	627.8	365.0	6.81	1040.0	604.6	11.28	1359.1	790.1	14.74	1846.7	1073.5	20.03
6 {0.6}		345.2	200.5	3.51	733.6	426.1	7.46	1215.1	705.9	12.36	1588.0	922.4	16.15	2157.6	1253.3	21.95
7 {0.7}		394.9	229.3	3.79	839.3	487.2	8.06	1390.3	807.1	13.35	1816.8	1054.8	17.45	2468.5	1433.1	23.70
8 {0.8}		444.7	258.0	4.05	945.0	548.4	8.62	1565.4	908.4	14.27	2045.7	1187.1	18.65	2779.5	1612.9	25.34
9 {0.9}		494.4	286.8	4.30	1050.7	609.5	9.14	1740.5	1009.7	15.14	2274.5	1319.4	19.78	3090.4	1792.7	26.88
10 {1.0}		544.2	315.6	4.53	1156.4	670.6	9.63	1915.6	1110.9	15.96	2503.4	1451.8	20.85	3401.4	1972.5	28.33

CAUTION AT SIZING

As the relieving capacity of lift type valve is lower than full bore type valve, ensure to select valve size with maximum relieving capacity.

In the application at the secondary side of pressure reducing valve for its failure protection, select a valve to blow out 10% of maximum flow through pressure reducing valve unless otherwise specified.

See the table for the valve set pressure, in the case that the set pressure values while using for the failure protection of pressure reducing valve are recommendable but not absolute.

Set pressure of reducing valve (kgf/cm ²){MPa}	Set pressure of safety valve (kgf/cm ²){MPa}
1{0.1} and under	+0.5{+0.05} and over
1{0.1} to 4{0.4}	+0.8{+0.08} and over
4{0.4} to 6{0.6}	+1.0{+0.1} and over
6{0.6} to 8{0.8}	+1.2{+0.12} and over