



USRP™ E312

Battery Operated

USRP™ E312

Product Overview

The battery operated USRP E312 offers a portable stand-alone software defined radio platform designed for field deployment. The flexible 2x2 MIMO AD9361 transceiver from Analog Devices provides up to 56 MHz of instantaneous bandwidth and spans frequencies from 70 MHz – 6 GHz to cover multiple bands of interest. RF filter banks in both the transmitter and receiver front-end enhances selectivity. The baseband processor uses the Xilinx Zynq 7020 SoC to deliver FPGA accelerated computations combined with stand-alone operation enabled by a dual-core ARM CPU. The USRP E312 includes a rich set of peripherals such as an integrated GPS receiver for position awareness and time synchronization, as well as two host USB ports for extending storage, I/O, and communication options with off-the-shelf devices. Users can rapidly prototype and deploy designs for mobile and embedded applications with tight size, weight, and power requirements. The USRP Embedded Series platform uses the OpenEmbedded framework to create custom Linux distributions tailored to application specific needs. The default operating system is pre-installed with the USRP Hardware Driver™ (UHD) software and a variety of third party development tools such as GNU Radio. Support for the RF Network on Chip (RFNoC™) FPGA development framework enables deterministic computations for real-time and wideband signal processing.

Applications

Spectrum Monitoring and Analysis

RF filter banks enhance the selectivity of the transceiver to accurately distinguish a broad range of spectral signals. The user-programmable FPGA enables deterministic computations for real-time spectrum analysis.

Mobile Radio and Unmanned Vehicle

The compact size and stand-alone capability of the USRP E312 provides a portable deployment solution with expansive peripherals for interaction with external systems.



Features

RF Capabilities

- 2 RX, 2 TX
- Filter banks
- 70 MHz to 6 GHz frequency range
- Up to 56 MHz of bandwidth

Baseband Processing

- Xilinx Zynq 7020
 - ARM Cortex A9 866 MHz dual-core
 - 7 Series FPGA
- 1 GB DDR3 RAM for ARM processor
- 512 MB DDR3 RAM for FPGA logic
- Up to 10 MS/s sample data transfer rate to ARM processor

Software

- UHD version 3.9.2 or later
- RFNoC
- GNU Radio
- C/C++
- Python

Synchronization

- PPS time reference

Power

- External DC power supply
- Internal 3200 mAh Li-ion battery

Peripherals

- 10/100/1000 BASE-T Ethernet
- Integrated GPS receiver
- 2 host USB ports
- 9-axis IMU

Form Factor

- 133 x 68 x 32 mm
- 446 g

Specifications¹

Specification	Typical	Unit
RF Performance²		
IIP3 (at typical NF)	-20	dBm
Power Output	> 10	dBm
Receive Noise Figure	< 8	dB
Conversion Performance and Clocks²		
ADC Sample Rate (Max.)	61.44	MS/s
ADC Resolution	12	bits
DAC Sample Rate (Max.)	61.44	MS/s
DAC Resolution	12	bits
Frequency Accuracy	±2.0	ppm
Temperature		
Operating Temperature Range	0 – 45	°C

Specification	Typical	Unit
Power		
DC Input	5 – 15	V
Power Consumption	2 – 6	W
Internal Battery		
Capacity	3200	mAh
Voltage	3.7	V
Charge Time	120	minutes
Full Load Battery Life ³	140	minutes
Physical		
Dimensions	133 x 68.2 x 31.8	mm
Weight	446	g

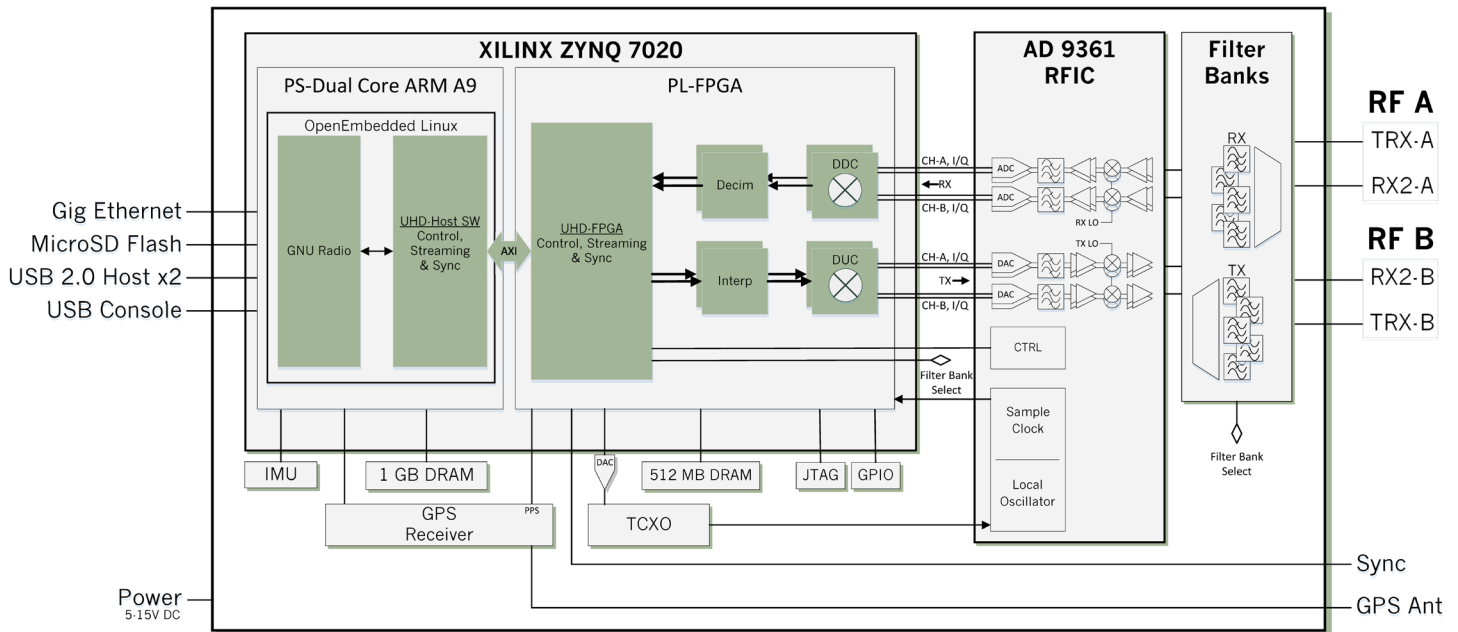

¹ All specifications are subject to change without notice.

² Additional RF and digitizer specifications can be found on the ADI 9361 data sheet. <http://www.analog.com/media/en/technical-documentation/data-sheets/AD9361.pdf>

³ Full load battery life is measured while the USRP E312 operates in 2x2 MIMO mode at 5 GHz center frequency, 1 MS/s sample rate, and maximum gain settings.

Specifications

RF Filter Bank Performance⁴

The USRP E312 contains both RX and TX filter banks. Filters are dynamically chosen based on user frequency selection. The RX filters reduce interference from out-of-band signals, while the TX filters suppress harmonics.

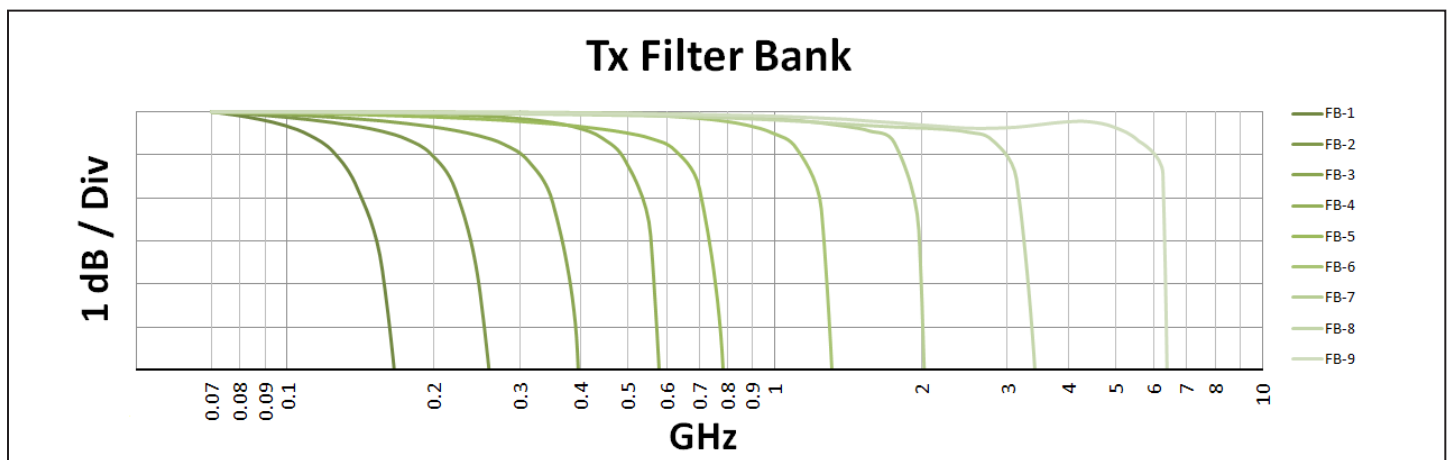
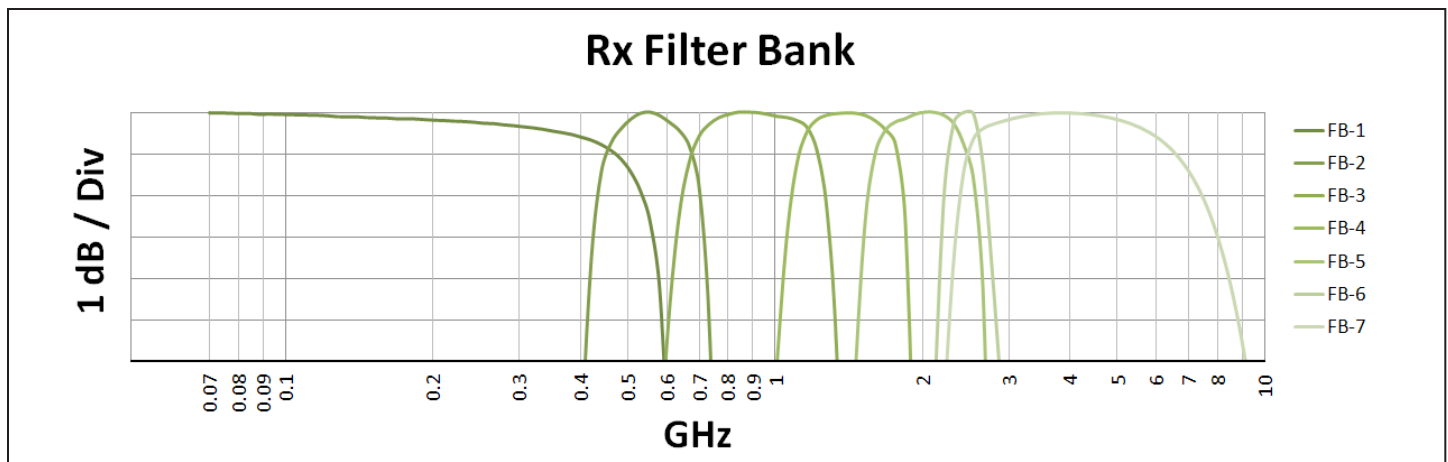

⁴ Normalized values based on component characteristics.

About Ettus Research

Ettus Research™, a National Instruments company, is the world's leading supplier of software defined radio platforms, including the USRP™ (Universal Software Radio Peripheral) family of products. The USRP platform supports multiple development environments on an expansive portfolio of high performance RF hardware, and enables algorithm design, exploration, prototyping, and deployment of next generation wireless technologies across a wide variety of applications spanning DC to 6 GHz such as cognitive radio, spectrum monitoring and analysis, remote sensing, advanced wireless prototyping, mobile radio, public safety, broadcast TV, satellite communication, and navigation.

