

**Materials / Surfaces:**

Input flange: Aluminum / Untreated  
Housing: Steel / Nitrocarburized and post-oxidized (black)  
Output flange: Aluminum / Untreated

Please see mounting instructions!

Please see operating manual!

Subject to modifications!

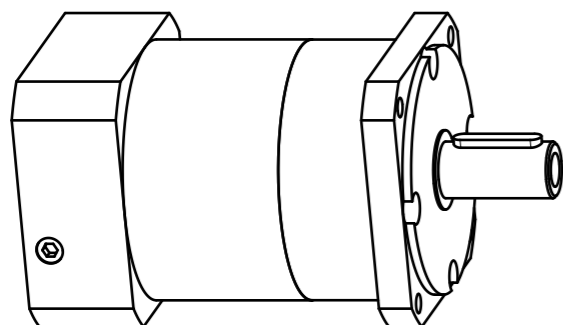

	Scale: 2:5	DIN A3	ISO
	Revision status: H from: 19.11.2015		
	Changed revision status: G from: 08.07.2015		
General tolerance DIN ISO 2768-cL	PLQE120-032-SSSA3AF-E19 /40/95/115/B5/M8		
Neugart GmbH Keltenstr. 16 D-77971 Kippenheim			Sheet 1/2

Technical data	Character	Unit	
Planetary gearbox - gearing type	-	-	Straight teeth
Number of stages	Z	-	2-stage
Output shaft bearing	-	-	Deep groove ball bearing
Seal	-	-	2RS bearing seal
Service Life (L10h)	$t_L$	h	30.000
Max. operating temperature	$T_{min} / T_{max}$	°C	-25 / +90
Protection class	-	-	IP 54
Lubrication (lifetime lubrication)	-	-	Standard lubrication (grease)
Installation position	-	-	Any
Max. bending moment based on the gearbox input flange (for motor weight) (1)	$M_b$	Nm	40
Motor flange precision	-	-	DIN 42955-N
Required motor shaft tolerance	-	-	j6; k6
Min. permissible motor shaft length	$L_{20 min}$	mm	22
Clamp screw tightening torque	$T_{A,K}$	Nm	16,5
Reference operating mode	-	-	S1
Reference operating factor	$K_A$	-	1
Reference speed	$n_2$	rpm	100
Reference ambient temperature	$T_{Amb}$	°C	20
Radial force for output bearing based on shaft center after L10h=20,000h with Fa=0N	$F_r 20.000h$	N	2950
Axial force for output bearing based on gearbox axis after L10h=20,000h with Fr=0N	$F_a 20.000h$	N	2500
Radial force for output bearing based on shaft center after L10h=30,000h with Fa=0N	$F_r 30.000h$	N	2400
Axial force for output bearing based on gearbox axis after L10h=30,000h with Fr=0N	$F_a 30.000h$	N	2100
Static radial force based on shaft center and T2=0Nm	$F_r Stat$	N	4000
Static axial force based on gearbox axis and T2=0Nm	$F_a Stat$	N	3800

Ratio-dependent data	Character	Unit	
Ratio	i	-	32
Nominal output torque No alternating torque (2)	$T_{2N}$	Nm	260
Nominal output torque Alternating torque permitted for 10,000,000 load changes (3)	$T_{2N 10Mio}$	Nm	132
Nominal output torque Alternating torque permitted for 100,000,000 load changes (3)	$T_{2N 100Mio}$	Nm	105
Max. output torque for 30,000 output shaft rotations	$T_{2max}$	Nm	416
Emergency stop torque permitted 1000 times	$T_{2stop}$	Nm	520
Idle torque for $n_1=3,000$ rpm and 20 °C gearbox temperature	$T_0$	Nm	0,45
Average thermal input speed at 50% T2N, S1, and T_Amb Operating temperature may not be exceeded!	$n_{1N 50\%}$	rpm	3500
Average thermal input speed at 100% T2N, S1, and T_Amb Operating temperature may not be exceeded!	$n_{1N 100\%}$	rpm	3500
Max. mechanical input speed Operating temperature may not be exceeded!	$n_{1 Limit}$	rpm	6500
Torsional backlash based on output shaft	$j_t$	arcmin	< 9
Torsional stiffness based on output shaft	$c_g$	Nm/arcmin	13,4
Efficiency at T2N, gearbox temperature 70 °C and $n_1=1,000$ rpm	$\eta$	%	95
Running noise at $n_1=3,000$ rpm without load at a distance of 1m	$Q_g$	dB(A)	65
Gearbox weight	$m_G$	kg	8,6
Mass moment of inertia based on clamping system diameter input	J	kgcm <sup>2</sup>	1,42

$$(1) \text{ Max. motor weight* in kg} = \frac{0,2 * M_b}{\text{motor length in m}}$$

- \* with symmetrically distributed motor weight
- \* with horizontal and stationary mounting

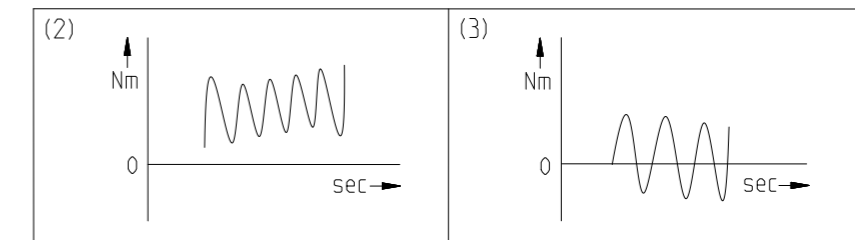

Subject to modifications!



PLQE120-032-SSSA3AF-E19  
/40/95/115/B5/M8

Sheet 2/2

Revision status: H from: 19.11.2015