

Flange output shaft (similar EN ISO 9409-1)

Materials / Surfaces:

Input flange: Aluminum / Untreated

Housing: Steel / Nitrocarburized and post-oxidized (black)

Output flange: Steel / Untreated

Please see mounting instructions!

Please see operating manual!

Subject to modifications!

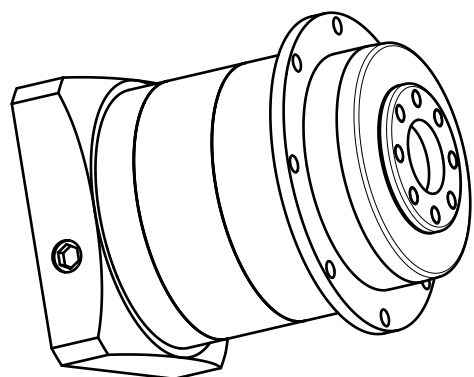

	Scale: 7:10	DIN A3	ISO
	Revision status: L from: 14.07.2016		
	Changed revision status: K from: 01.07.2013		
General tolerance DIN ISO 2768-cL	PLFN064-100-RSSD3AD-Z11 /23/60/82/B5/M5		
Neugart GmbH Keltenstr. 16 D-77971 Kippenheim			Sheet 1/2

Technical data	Character	Unit	
Planetary gearbox - gearing type	-	-	Straight teeth
Number of stages	Z	-	2-stage
Output shaft bearing	-	-	Tapered roller bearing
Seal	-	-	Radial shaft seal
Service life (L10h)	t_L	h	20.000
Max. operating temperature	T_{min} / T_{max}	°C	-25 / +90
Protection class	-	-	IP 65
Lubrication (lifetime lubrication)	-	-	Standard lubrication (oil)
Installation position	-	-	Any
Max. bending moment based on the gearbox input flange (for motor weight) (1)	M_b	Nm	18
Motor flange precision	-	-	DIN 42955-R
Required motor shaft tolerance	-	-	j6; k6
Min. permissible motor shaft length	$L_{20\ min}$	mm	17
Clamp screw tightening torque	$T_{A,K}$	Nm	4,5
Reference operating mode	-	-	S1
Reference operating factor	K_A	-	1
Reference speed	n_2	rpm	100
Reference ambient temperature	T_{Amb}	°C	20
Radial force for output bearing based on shaft end after L10h=20,000h with Fa=0N	$F_r\ 20.000h$	N	2400
Axial force for output bearing based on gearbox axis after L10h=20,000h with Fr=0N	$F_a\ 20.000h$	N	4300
Radial force for output bearing based on shaft end after L10h=30,000h with Fa=0N	$F_r\ 30.000h$	N	2100
Axial force for output bearing based on gearbox axis after L10h=30,000h with Fr=0N	$F_a\ 30.000h$	N	3800
Static radial force based on shaft end and T2=0Nm	$F_r\ Stat$	N	2400
Static axial force based on gearbox axis and T2=0Nm	$F_a\ Stat$	N	4300

$$(1) \text{ Max. motor weight* in kg} = \frac{0,2 * M_b}{\text{motor length in m}}$$

- * with symmetrically distributed motor weight
- * with horizontal and stationary mounting

Ratio-dependent data	Character	Unit	
Ratio	bii	-	100
Nominal output torque	T_{2N}	Nm	27
Max. output torque for 30,000 output shaft rotations	T_{2max}	Nm	43
Emergency stop torque permitted 1000 times	T_{2Stop}	Nm	80
Idle torque for $n_1=3,000$ rpm and 20 °C gearbox temperature	T_0	Nm	0,2
Average thermal input speed at 50% T2N, S1, and T_Amb Operating temperature may not be exceeded!	$n_{1N\ 50\%}$	rpm	4500
Average thermal input speed at 100% T2N, S1, and T_Amb Operating temperature may not be exceeded!	$n_{1N\ 100\%}$	rpm	4500
Max. mechanical input speed Operating temperature may not be exceeded!	$n_{1\ Limit}$	rpm	14000
Torsional backlash based on output shaft	j_t	arcmin	< 2
Torsional stiffness based on output shaft	c_g	Nm/arcmin	11
Efficiency at T2N, gearbox temperature 70 °C and $n_1=1,000$ rpm	η	%	68
Running noise at $n_1=3,000$ rpm without load at a distance of 1m	Q_g	dB(A)	60
Gearbox weight	m_G	kg	2,2
Mass moment of inertia based on clamping system diameter input	J	kgcm ²	0,209

Subject to modifications!



PLFN064-100-RSSD3AD-Z11
/23/60/82/B5/M5

Sheet 2/2

Revision status: L from: 14.07.2016