

USRP™ B200mini Series

Product Overview

The USRP B200mini Series delivers a 1x1 SDR/cognitive radio in the size of a business card. With a wide frequency range from 70 MHz to 6 GHz and a user-programmable Xilinx Spartan-6 FPGA, this flexible and compact platform is ideal for both hobbyist and OEM applications. The RF front end uses the Analog Devices AD9364 RFIC transceiver with 56 MHz of instantaneous bandwidth. The board is bus-powered by a high-speed USB 3.0 connection for streaming data to the host computer. The USRP B200mini Series also includes connectors for GPIO, JTAG, and synchronization with a 10 MHz clock reference or PPS time reference input signal. There are three configurations in this product family with options for a larger or industrial-grade FPGA. An optional enclosure accessory is available, which extends the operating temperature ranges of these devices. The USRP Hardware Driver™ (UHD) software API supports all USRP products and enables users to efficiently develop applications then seamlessly transition designs between platforms as requirements expand.

Applications

Hobbyists and New Users

The powerful UHD software API reduces the learning curve and provides a quick start experience for new users and long-time hobbyists interested in AM/FM applications, cellular communication, and algorithm exploration.

Wireless Signal Discovery and Analysis

The content-rich GNU Radio community provides a wide range of tools and algorithms that enable discovery and analysis of air interface protocols.

OEM and Integration

The compact form factor and cost-effective design of the B200mini Series make it ideal for integration into larger systems for prototyping and deployment. The 10 MHz ref/PPS and GPIO features provide seamless synchronization and control capability.

¹ The USRP B200mini and B200mini-i variants were released before the B205mini-i variant and are therefore supported by UHD version 3.9.0 or later. The USRP B205mini-i is supported by version 3.9.2 or later.

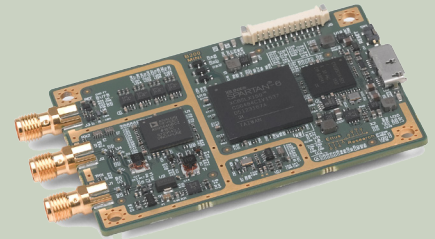

Features

Device Variants

- B200mini (LX75 C-Grade FPGA)
- B200mini-i (LX75 I-Grade FPGA)
- B205mini-i (LX150 I-Grade FPGA)

RF Capabilities

- 1 TX, 1 RX
- 70 MHz to 6 GHz frequency range
- Up to 56 MHz bandwidth

Software

- UHD version 3.9.2 or later¹
- GNU Radio
- C/C++
- Python

High-Speed Interface and Power

- USB 3.0
- USB powered

Synchronization

- 10 MHz clock reference or PPS time reference

Peripherals

- GPIO
- JTAG

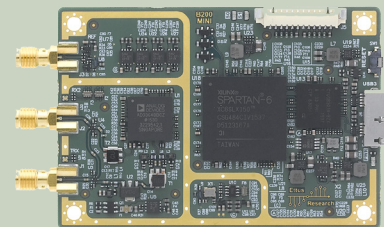

Specifications²

Specification	Typical	Unit
RF Performance³		
IIP3 (at typical NF)	-20	dBm
Power Output	> 10	dBm
Receive Noise Figure	< 8	dB
Conversion Performance and Clocks³		
ADC Sample Rate (Max.)	61.44	MS/s
ADC Resolution	12	bits
DAC Sample Rate (Max.)	61.44	MS/s
DAC Resolution	12	bits
Host Sample Rate (16b)	61.44	MS/s
Frequency Accuracy	±2.0	ppm

Specification	Typical	Unit
Power		
USB Power	5	V
Physical		
Dimensions	83.3 x 50.8 x 8.4	mm
Weight	24.0	g

Operating Temperature Range			
Device	Board Only	With Enclosure ⁴	Unit
B200mini	0 – 40	-20 – 60	°C
B200mini-i	0 – 45	-40 – 75	°C
B205mini-i	0 – 45	-40 – 75	°C

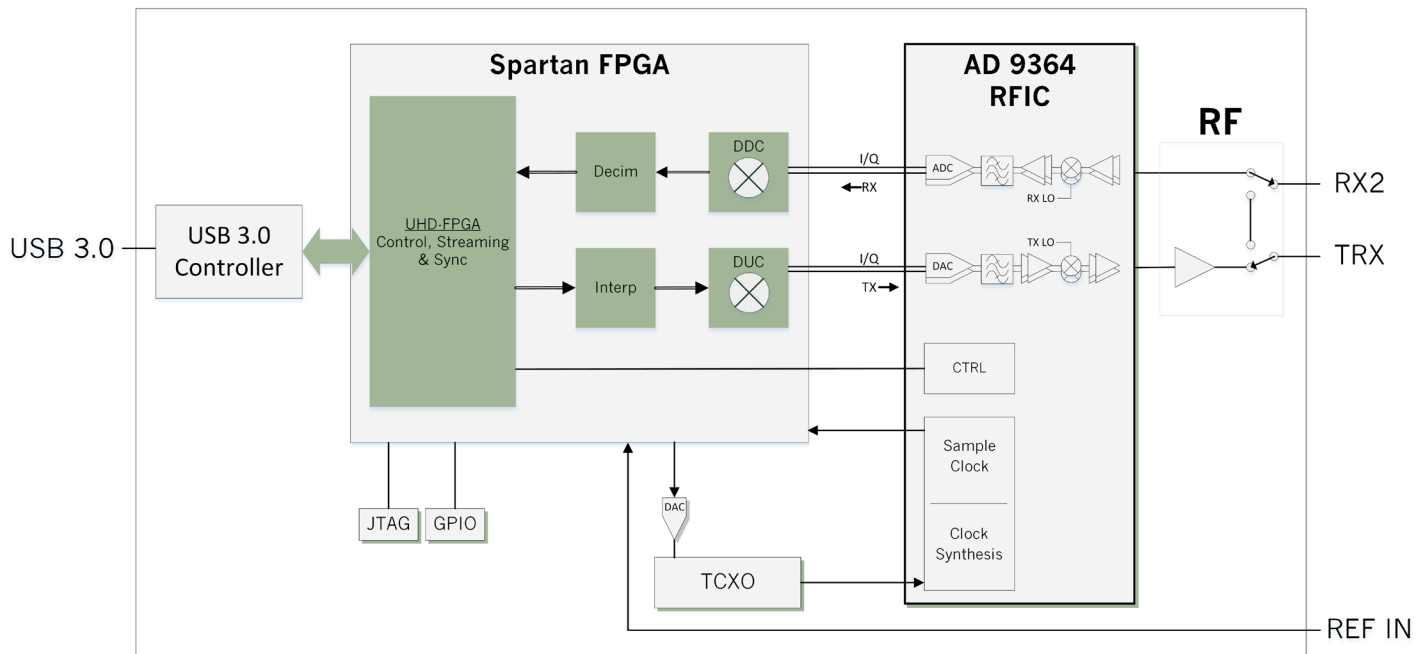

² All specifications are subject to change without notice.

³ Additional RF and digitizer specifications can be found on the ADI 9364 data sheet. <http://www.analog.com/media/en/technical-documentation/data-sheets/AD9364.pdf>

⁴ Enclosures are optional accessories that can be purchased through the Ettus Research website.

About Ettus Research

Ettus Research™, a National Instruments company, is the world's leading supplier of software defined radio platforms, including the USRP™ (Universal Software Radio Peripheral) family of products. The USRP platform supports multiple development environments on an expansive portfolio of high performance RF hardware, and enables algorithm design, exploration, prototyping, and deployment of next generation wireless technologies across a wide variety of applications spanning DC to 6 GHz such as cognitive radio, spectrum monitoring and analysis, remote sensing, advanced wireless prototyping, mobile radio, public safety, broadcast TV, satellite communication, and navigation.

