

Like the EG Gland, Conax Technologies EGT Glands electrically and/or thermally isolate single electrodes, tubes or temperature sensors for use in vacuum furnaces, liquid level probes, transformers, environmental chambers, power leads and more. These bare electrical feedthroughs also seal against gases and liquids and resist element movements under pressure. The EGT gland differs from the EG gland in that the insulator and sealant are provided as a single continuous PTFE piece to accommodate higher voltage/amperage at lower pressures.

EGT gland bodies with NPT threads or SAE threads are constructed from 303SST standard. Weld-neck style glands are constructed from 316LSST standard. Caps and followers for all styles are constructed from 303SST standard. Many optional materials are also available. See page 9 for details. Cap Style A offers a mounting thread only. Cap Style B provides threading on both ends for attachment to conduit or terminal heads. Alternative sealant materials are available. Please consult a Conax Technologies sales engineer for custom needs.

Conductors are available in Copper, Nickel and 303SST. Use of Nickel rather than Copper is recommended in oxidizing atmospheres. For further information on conductor selection, see page 11. Custom conductors, such as nickel-plated copper, are available. Please consult factory.

- Temperature Range: -300° F to +450° F (-185° C to +232° C)
- Pressure Range: Vacuum to 2,500 PSIG (170 bar) – see Pressure Ratings in Specifications Chart.
- Voltage to 8000 VDC
- Amperage to 525 amp
- Supplied with or without conductor

Accessories

The replaceable sealant permits repeated use of the same fitting. Electrodes can be easily assembled or replaced in the field. To replace the sealant or element, simply loosen the cap, replace the necessary items, relubricate and retorque the cap.

Glands are supplied factory lubricated. When reused, the glands should be relubricated to maintain the published torque and pressure ratings. If glands are cleaned prior to assembly, they should be relubricated. On weld mount models, the heat from the welding process will destroy the lubricant. These models must also be relubricated prior to use. See page 103 for information on our lubrication kit.

To order a Replacement Sealant, order RS – (Gland) – (Diameter)

Example: RS-EGT-093

For replacement conductors, see the Accessories section on page 102.

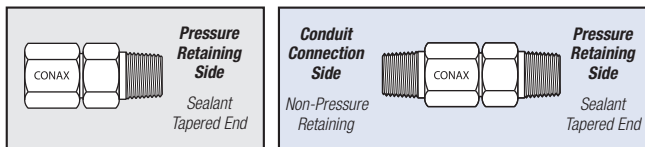

Type A has mounting thread only.

Type B has cap end threaded. B Cap NPT matches the standard mounting NPT.

Catalog Numbering System

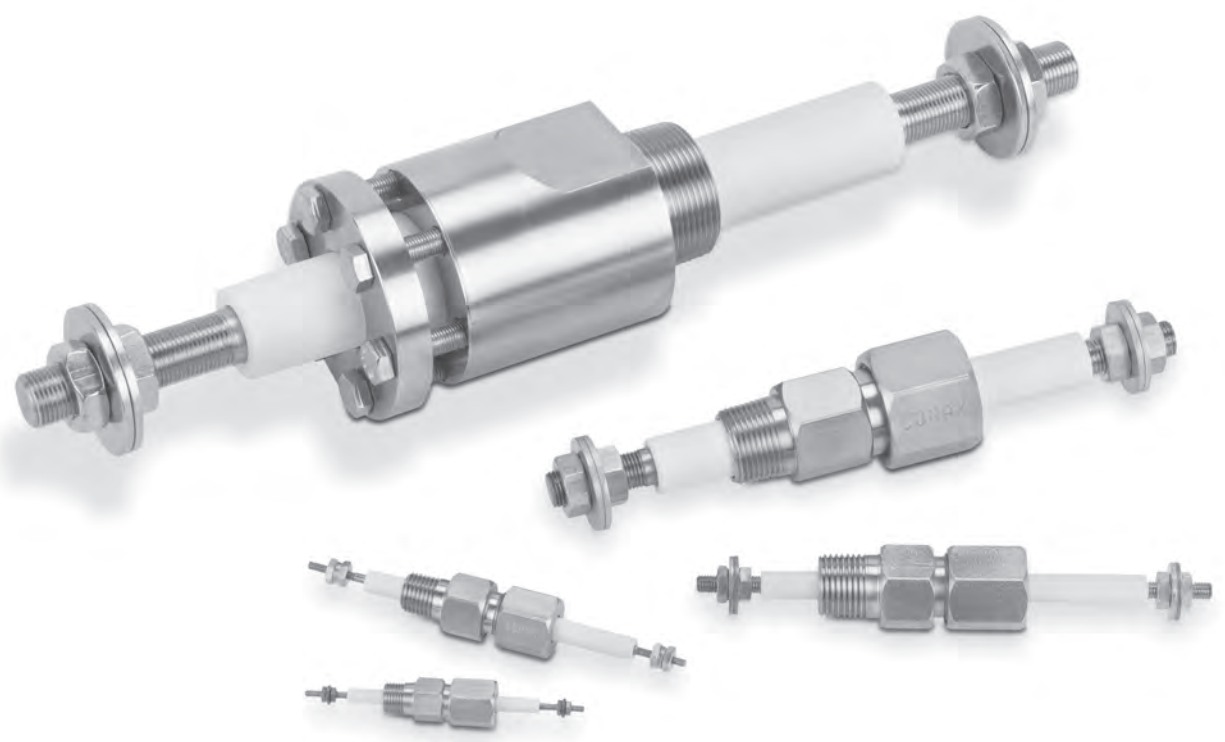
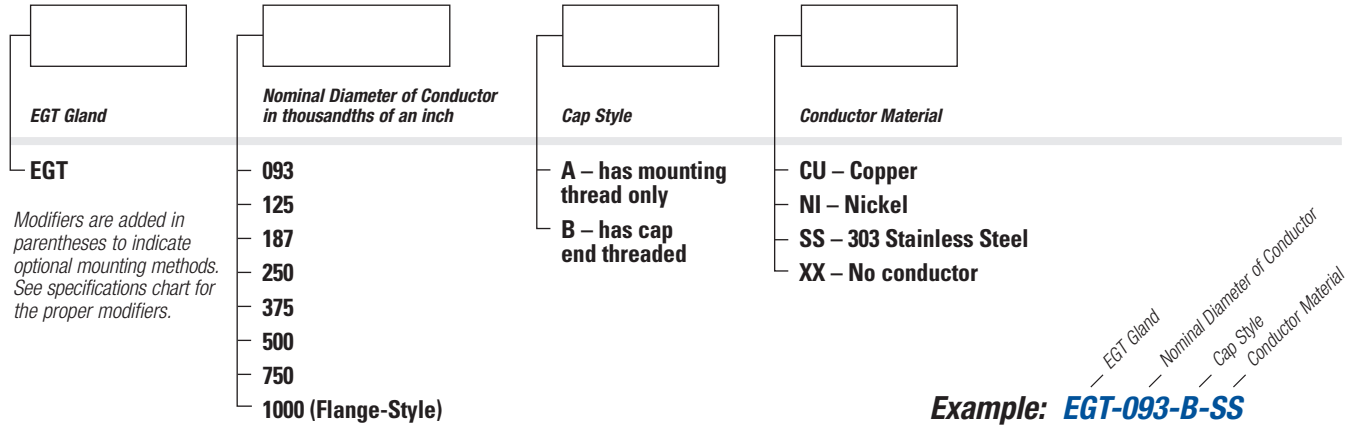

High Performance Electrode Gland With Single Peak™ Insulator (up to 8,000 volts) for pressures up to 7700 PSI (530 BAR). See Bulletin 6068 for more information.

Specifications

Catalog Number	Conductor				Amperage Rating (@ 30°C, 90°C max)			Voltage Rating DC	Length 'A'		Length 'B'		Hex Size				Pressure Rating PTFE	
	Diam. IN	Std. Length IN	Diam. MM	Std. Length MM	CU	NI	SS		IN	MM	IN	MM	Body IN	Cap IN	Body MM	Cap MM	PSIG	BAR
Standard 1/8 NPT																		
EGT-093	0.093	3.188	2.36	80.96	20	10	3	4000	1.19	30.2	1.56	39.7	0.500	0.500	12.7	12.7	2,500	172
Weld Neck (Weld Neck Length 0.39", Diameter 0.405")**																		
EGT(SWM1/S316L)-093	0.093	3.188	2.36	80.96	20	10	3	4000	1.19	30.2	1.56	39.7	0.500	0.500	12.7	12.7	2,500	172
SAE 1/2 -20 Thread Mount (formerly MS)																		
EGT(MSE5/-)093	0.093	3.188	2.36	80.96	20	10	3	4000	1.25	31.8	1.63	41.4	0.750	0.500	19.1	12.7	2,500	172
Standard 1/4 NPT																		
EGT-125	0.120	5.000	3.05	127.00	40	15	6	8000	2.00	50.8	2.63	66.7	0.750	0.750	19.1	19.1	1,200	83
Weld Neck (Weld Neck Length 0.59", Diameter 0.54")**																		
EGT(SWM2/S316L)-125	0.120	5.000	3.05	127.00	40	15	6	8000	2.00	50.8	2.63	66.7	0.750	0.750	19.1	19.1	1,200	83
SAE 9/16 -18 Thread Mount (formerly MS)																		
EGT(MSE6/-)125	0.120	5.000	3.05	127.00	40	15	6	8000	2.00	50.8	2.63	66.7	0.813	0.750	20.7	19.1	1,200	83
Standard 1/2 NPT																		
EGT-187	0.182	6.500	4.62	165.10	60	25	9	8000	2.56	65.1	3.31	84.1	1.000	1.000	25.4	25.4	1,600	110
EGT-250	0.245	6.500	6.22	165.10	95	40	15	8000	2.56	65.1	3.31	84.1	1.000	1.000	25.4	25.4	1,200	83
Weld Neck (Weld Neck Length 0.78", Diameter 0.84")**																		
EGT(SWM4/S316L)-187	0.182	6.500	4.62	165.10	60	25	9	8000	2.56	65.1	3.31	84.1	1.000	1.000	25.4	25.4	1,600	110
EGT(SWM4/S316L)-250	0.245	6.500	6.22	165.10	95	40	15	8000	2.56	65.1	3.31	84.1	1.000	1.000	25.4	25.4	1,200	83
SAE 3/4-16 Thread Mount (formerly MS)																		
EGT(MSE8/-)187	0.182	6.500	4.62	165.10	60	25	9	8000	2.56	65.1	3.31	84.1	1.000	1.000	25.4	25.4	1,600	110
EGT(MSE8/-)250	0.245	6.500	6.22	165.10	95	40	15	8000	2.56	65.1	3.31	84.1	1.000	1.000	25.4	25.4	1,200	83
Standard 3/4 NPT																		
EGT-375	0.370	8.500	9.40	215.90	160	65	24	8000	2.88	73.0	3.63	92.1	1.250	1.500	31.8	38.1	600	41
EGT-500	0.495	8.500	12.57	215.90	200	80	30	8000	2.88	73.0	3.63	92.1	1.250	1.500	31.8	38.1	600	41
Weld Neck (Weld Neck Length 0.79", Diameter 1.05")**																		
EGT(SWM5/S316L)-375	0.370	8.500	9.40	215.90	160	65	24	8000	2.88	73.0	3.63	92.1	1.250	1.500	31.8	38.1	600	41
EGT(SWM5/S316L)-500	0.495	8.500	12.57	215.90	200	80	30	8000	2.88	73.0	3.63	92.1	1.250	1.500	31.8	38.1	600	41
SAE 1-5/16 -12 Thread Mount (formerly MS)																		
EGT(MSE16/-)375	0.370	8.500	9.53	215.90	160	65	24	8000	2.88	73.0	3.63	92.1	1.625	1.500	41.3	38.1	600	41
EGT(MSE16/-)500	0.495	8.500	12.57	215.90	200	80	30	8000	2.88	73.0	3.63	92.1	1.625	1.500	41.3	38.1	600	41
Standard 1 NPT																		
EGT-750	0.745	9.250	18.92	234.95	400	165	60	8000	3.50	88.9	4.50	114.3	1.750	2.000	44.5	50.8	600	41
Weld Neck (Weld Neck Length .98", Diameter 1.315")**																		
EGT(SWM6/S316L)-750	0.745	9.250	18.92	234.95	400	165	60	8000	3.50	88.9	4.50	114.3	1.750	2.000	44.5	50.8	600	41

CATALOG NUMBER	Conductor				Amperage Rating (@ 30°C, 90°C max)			Voltage Rating DC	Length 'A'		Length 'B'		Flange/Body Diameter		Pressure Rating PTFE	
	Diam. IN	Std. Length IN	Diam. MM	Std. Length MM	CU	NI	SS		IN	MM	IN	MM	IN	MM	PSIG	BAR
STANDARD 1-1/4 NPT																
EGT-1000	0.995	10.000	25.27	254.00	525	240	72	8000	3.75	95.3	NA	NA	3.000	76.2	100	7
WELD NECK (WELD NECK LENGTH .1.01", DIAMETER 1.66")**																
EGT(SWM7/S316L)-1000	0.995	10.000	25.27	254.00	525	240	72	8000	3.75	95.3	NA	NA	3.000	76.2	100	7

Note: EGT-750 and EGT-1000 are not available with SAE threads.

* Hex size for the body and cap are the same unless a cap size is provided in parentheses.

** Weld neck models require relubrication prior to use.

NA = Not Applicable

All pressure and torque ratings were determined at 68° F (20° C) using a solid electrode as the element. Pressure ratings may degrade at higher temperatures. Pressure rating guide values are provided for glands with elements restrained by the compressed sealant. Higher pressure may be attained with additional element restraints. For proper assembly of these sealing glands, see the Assembly Instructions provided on pages 106-119.

5001D

SINGLE ELECTRODE SEALING (to 8000 Volts) ■ EGT SERIES

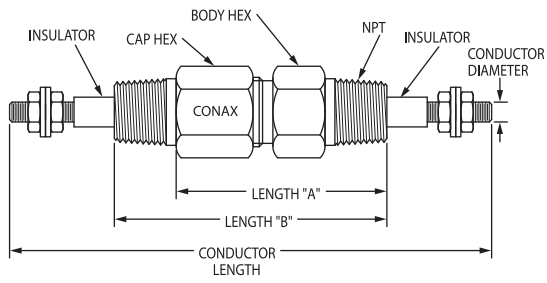

Standard NPT

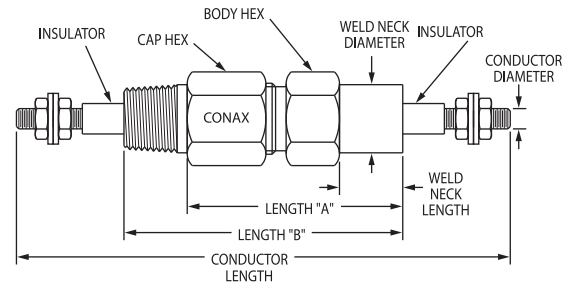

Weld Neck Mount

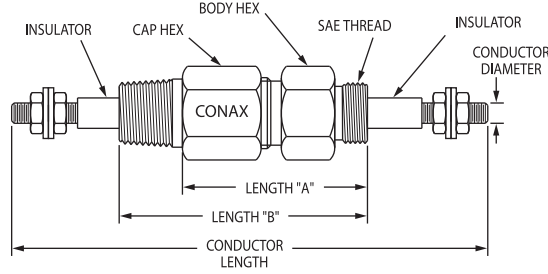

SAE Thread Mount

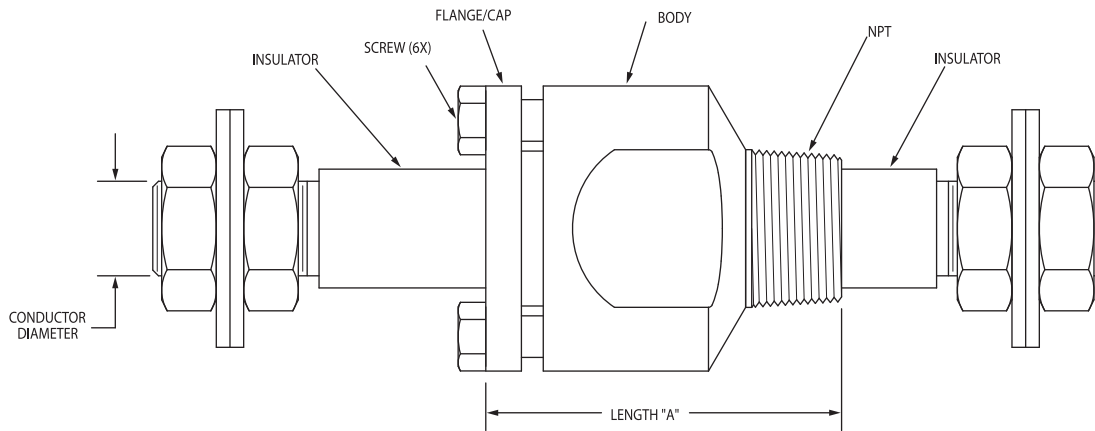

EGT-1000 NPT

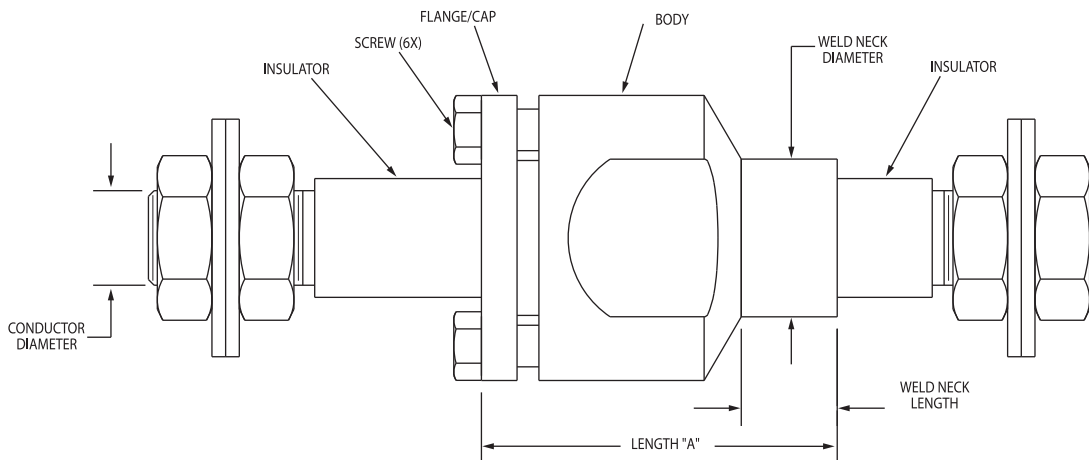

**EGT-1000
Weld Neck Mount**

HIGH DENSITY