

BILL OF MATERIAL (CS BODY/416SS TRIM)					BILL OF MATERIAL (316SS BODY/316SS TRIM)					BILL OF MATERIAL (ALL 316SS)							
NO.	NAME OF PART	QTY.	MATERIAL	PART NO.	SPECIFICATION	NO.	NAME OF PART	QTY.	MATERIAL	PART NO.	SPECIFICATION	NO.	NAME OF PART	QTY.	MATERIAL	PART NO.	SPECIFICATION
1	BODY, BOTTOM VALVE	1	CARBON STEEL	PER ORDER	A105	1	BODY, BOTTOM VALVE	1	316/316LSS	PER ORDER	A182 GR.F316/F316L	1	BODY, BOTTOM VALVE	1	316/316LSS	PER ORDER	A182 GR.F316/F316L
2	STEM	1	416SS	V11955 U3	QQ-5-763	2	STEM	1	316/316LSS	V11955 TL2	A479	2	STEM	1	316/316LSS	V11955 TL2	A479
3	TAILPIECE, TANK CONN.	1	LOW TEMP CS	PER ORDER	A350 GR.LF2	3	TAILPIECE, TANK CONN.	1	316/316LSS*	PER ORDER		3	TAILPIECE, TANK CONN.	1	316/316LSS*	PER ORDER	
4	NUT, TAILPIECE	1	LOW TEMP CS	PER ORDER	A350 GR.LF2	4	NUT, TAILPIECE	1	LOW TEMP CS	PER ORDER	A350 GR.LF2	4	NUT, TAILPIECE	1	316/316LSS	PER ORDER	A276 GR.F316/F316L
5	PACKING RING	1	LOW TEMP CS	P254 1 A32	A350 GR.LF2	5	PACKING RING	1	316/316LSS	P254 1 T2	A479	5	PACKING RING	1	316/316LSS	P254 1 T2	A479
6	PACKING	3	GRAPHITE/NICR	G259		6	PACKING	3	GRAPHITE/NICR	G259		6	PACKING	3	GRAPHITE/NICR	G259	
7	GLAND	1	LOW TEMP CS	V10167 A32	A350 GR.LF2	7	GLAND	1	LOW TEMP CS	V10167 A32	A350 GR.LF2	7	GLAND	1	316/316LSS	V10167 T2	
8	NUT, GLAND	1	LOW TEMP CS	P70 6 A32	A350 GR.LF2	8	NUT, GLAND	1	LOW TEMP CS	P70 6 A32	A350 GR.LF2	8	NUT, GLAND	1	316/316LSS	P70 6 T2	A276 GR.F316/F316L
9	BALL CHECK	1	440SS	P1 1		9	BALL CHECK	1	316SS	P1 T2	QQ-5-763	9	BALL CHECK	1	316SS	P1 T2	QQ-5-763
10	STOP, BALL CHECK	1	316SS	V13113 T		10	STOP, BALL CHECK	1	316SS	V13113 T		10	STOP, BALL CHECK	1	316SS	V13113 T	
11	HANDWHEEL	1	CARBON STEEL	PD325 D1		11	HANDWHEEL	1	CARBON STEEL	PD325 D1		11	HANDWHEEL	1	CARBON STEEL	PD325 D1	
12	NUT, STEM	1	CARBON STEEL	P78 6 A12	A563	12	NUT, STEM	1	CARBON STEEL	P78 6 A12	A563	12	NUT, STEM	1	316SS	P78 6 T	
13	TAILPIECE, GAGE CONN.	1	LOW TEMP CS	PER ORDER	A350 GR.LF2	13	TAILPIECE, GAGE CONN.	1	316/316LSS*	PER ORDER		13	TAILPIECE, GAGE CONN.	1	316/316LSS*	PER ORDER	
14	NUT, TAILPIECE	1	LOW TEMP CS	PER ORDER	A350 GR.LF2	14	NUT, TAILPIECE	1	LOW TEMP CS	PER ORDER	A350 GR.LF2	14	NUT, TAILPIECE	1	316/316LSS	PER ORDER	A276 GR.F316/F316L
15	RATING TAG	1	304SS	V22038 2		15	RATING TAG	1	304SS	V22038 2		15	RATING TAG	1	304SS	V22038 2	

*14-4PHSS FOR SPHERICAL TAILPIECES

*17-4PHSS FOR SPHERICAL TAILPIECES

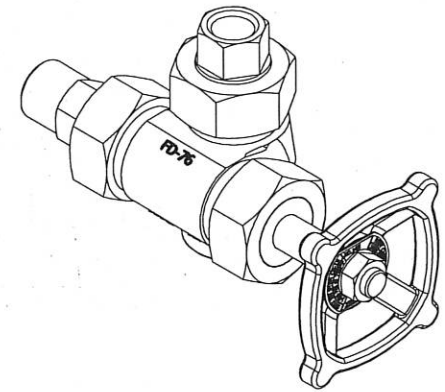

NOTES:

- DIMENSIONS IN INCHES W/ mm EQUIVALENTS IN BRACKETS
- TOP AND BOTTOM VALVES SAME EXCEPT OPPOSITE HANDING (I.E., MIRROR IMAGES) (BOTTOM LEFT HAND VALVE SHOWN)
- VALVE RATING - CARBON STEEL & 316SS:
2400 PSI @ 100°F, 1323 PSI @ 800°F
(169 KG/CM² @ 38°C, 93 KG/CM² @ 427°C)
- SEE TABLES FOR AVAILABLE STANDARD CONNECTIONS
- REFER TO THE FOLLOWING (FOR):
* CATALOG BULLETIN 3100.50 (ADDITIONAL INFORMATION)
* IOM BULLETIN 3500.07 (INSTRUCTIONS)
- VALVE "TRIM" = STEM & BALL CHECK
- CONSULT FACTORY FOR ALTERNATE MATERIAL OPTIONS

UNION TANK CONNECTION ("A" DIMENSION)									
1/2" MNPT (OR MSW)	1/2" FNPT (OR FSW)	1/2" MNPT SPH. (OR MSW)	1/2" FNPT SPH. (OR FSW)	3/4" MNPT	3/4" MSW	3/4" FNPT	3/4" MNPT SPH. (OR MSW)	1" MNPT (OR MSW)	
3.688 [94]	2.813 [71]	4.313 [110]	3.438 [87]	3.688 [94]	4.500 [114]	2.813 [71]	4.313 [110]	4.125 [105]	
UNION GAGE CONNECTION ("B" DIMENSION)									
1/2" MNPT (OR MSW)	1/2" FNPT (OR FSW)	1/2" MNPT SPH. (OR MSW)	1/2" FNPT SPH. (OR FSW)	3/4" MNPT	3/4" MSW	3/4" FNPT	3/4" MNPT SPH. (OR MSW)	1" MNPT (OR MSW)	
3.563 [91]	2.688 [68]	4.188 [106]	3.313 [84]	3.563 [91]	3.563 [91]	2.688 [68]	4.188 [106]	4.000 [102]	
VENT / DRAIN CONNECTION									
1/2" OR 3/4" FNPT (OR FSW) ONLY									

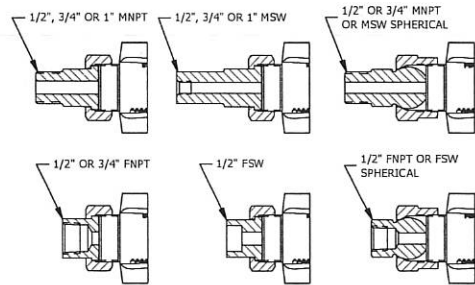
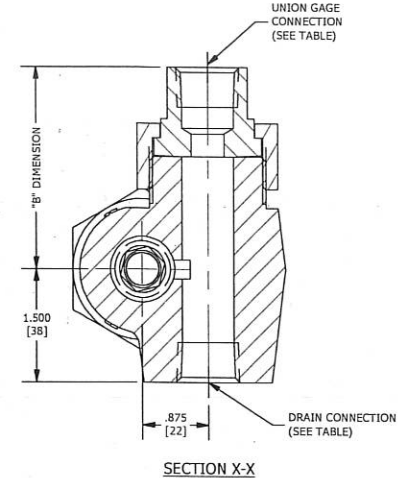
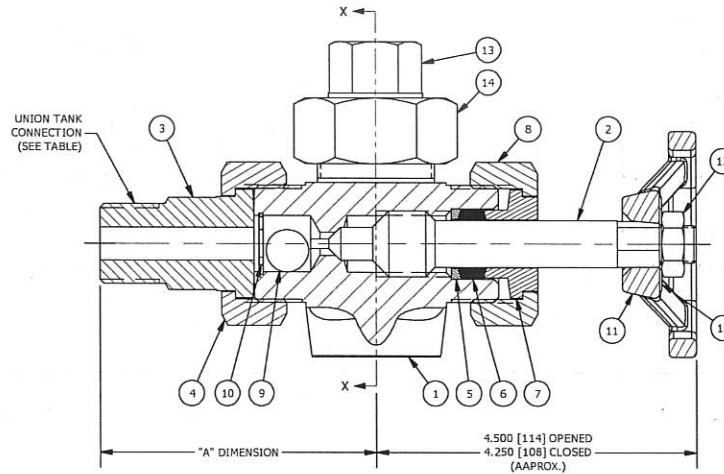

TANK & GAGE CONNECTION
(3/4" FSW UNION CONNECTION NOT AVAILABLE AS STANDARD)

REV	DATE	UPDATE BOM	BY
1	2/22/2018	UPDATE BOM	JLI

MANUFACTURED BY
Clark-Reliance®
 16633 FOLTZ PARKWAY
 STRONGSVILLE, OH 44149 USA
 (440) 572-1500 | www.clarkreliance.com
 © Clark-Reliance® Corporation. All Rights Reserved.

JERGUSON®
 #147 OFFSET VALVE (PLAIN-CLOSING)
 UNION TANK & GAGE CONNECTIONS

DRAWN: DDenk	REV.:
CHECKED: MK	
DATE: 7/8/2013	
REVISION: 1	
DRAWING NO.:	
147	1