

BRZ

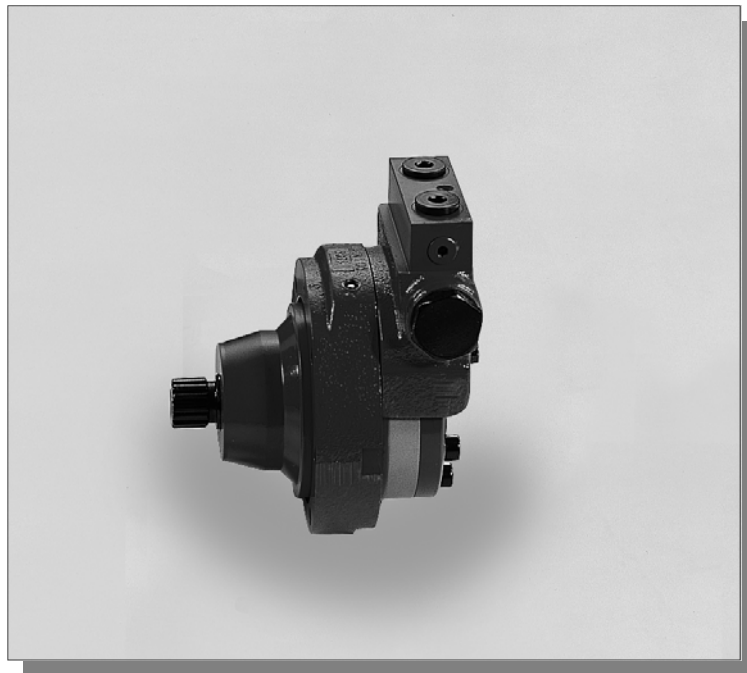

MOTORI CORTI PER RIDUTTORI

SHORT MOTORS FOR GEAR BOXES

CARATTERISTICHE DEI MOTORI MOTORS FEATURES



MOTORI CORTI PER RIDUTTORE

BRZ - Motori idraulici con organo motore tipo roller e distribuzione radiale. Disponibili nelle cilindrata da 50 a 400 cm³/giro per potenze sino a 13 kW. Sono disponibili valvole flangiabili per il controllo della traslazione e attacco per lo sblocco freno.

- Versioni:
 - **BRZL**: Motore con bocche filettate.
 - **BRZV**: Motore predisposto per l'utilizzo delle valvole opzionali.
- Valvole opzionali ed accessori:
 - **VCT11-SF**: Valvola controllo traslazione standard.
 - **VCT11-AF**: Valvola controllo traslazione con selettore apertura freno.
 - **CMZ**: Collettore modulare.



SHORT MOTOR FOR GEAR BOXES

BRZ - Orbital motor with roller design and spool valve distributor. Motion control valve and disengagement brake port as optional. Available with displacement from 50 up to 400 cm³/giro [from 3.05 up to 24.4 in³/rev and power up to 13 kW [17.4 hp].

- Versions:
 - **BRZL**: Threaded ports motor.
 - **BRZV**: Valves version motor.
- Optional valves and accessories:
 - **VCT11-SF**: Standard motion control valve.
 - **VCT11-AF**: Motion control valve with disengagement brake port.
 - **CMZ**: Flangeable manifold.

CODICE DI ORDINAZIONE ORDERING CODE

Serie Series		Cilindrata Displacement		Albero Shaft		Valvola Valve		Opzioni Options	
BRZV		50		S14		VCT 11 AF			
CODICE CODE	Serie Series	CODICE CODE	Cilindrata Displacement	CODICE CODE	Albero Shaft	CODICE CODE	Valvola** Valve**	CODICE CODE	Opzioni Options
BRZV	Motore BRZV BRZV Motor	50	51.6 cm ³ /giro [3.14 in ³ /rev]	S14	Scanalato B 25x22 DIN 5482 B 25x22 DIN 5482 Splined				Nessuna Opzione Without Option
BRZL	Motore BRZL (*) BRZL Motor (*)	65	64.9 cm ³ /giro [4.9 in ³ /rev]			VCT 11 SF	VCT 11 SF	HPS	Guarnizione alta pressione Pressure high seal
		80	80.4 cm ³ /giro [4.9 in ³ /rev]			VCT11 AF	VCT11 AF	TAC-U	Tachimetro Tachometer
		100	100 cm ³ /giro [6.1 in ³ /rev]			VCT 11 SF SAE	VCT 11 SF SAE		
		130	125.7 cm ³ /giro [7.66 in ³ /rev]			VCT11 AF SAE	VCT11 AF SAE		
		160	160 cm ³ /giro [9.76 in ³ /rev]			CMZ SF	CMZ SF		
		200	200 cm ³ /giro [12.2 in ³ /rev]			CMZ AF	CMZ AF		
		250	250 cm ³ /giro [15.2 in ³ /rev]						
		315	314.5 cm ³ /giro [19.1 in ³ /rev]						
		400	393 cm ³ /giro [23.9 in ³ /rev]						

*SPECIALE A RICHIESTA - SPECIAL ON REQUEST

** Solo motore BRZV - Only BRZV motor

In caso di caratteristiche non elencate, contattare Uff. Tecnico.
Please contact technical department for not listed features.

Motore Motor	Cilindrata Displacement cm ³ /rev [in ³ /rev]	Pressione max ingresso Max. input pressure bar [psi]		Pressione diff. max. Max. differential pressure bar [psi]		Coppia max. Max. torque Nm [lbf-ft]		Portata max. Max. flow l/min [U.S. gpm]		Velocità max. Max. speed giri/min [rpm]		Potenza max. Max. horsepower kW [hp]	
		Cont Int ⁽¹⁾ Peak ⁽²⁾	175 [2537] 200 [2900] 225 [3262]	Cont Int ⁽¹⁾ Peak ⁽²⁾	140 [2030] 175 [2540] 225 [3262]	Cont Int ⁽¹⁾	103 [75.9] 126 [92.8]	Cont Int ⁽¹⁾	40 [10.6] 50 [13.2]	Cont Int ⁽¹⁾	775 969	Cont Int ⁽¹⁾	6.8 [9.1] 8.4 [11.2]
BRZ 50	51.6 [3.14]	Cont Int ⁽¹⁾ Peak ⁽²⁾	175 [2537] 200 [2900] 225 [3262]	Cont Int ⁽¹⁾ Peak ⁽²⁾	140 [2030] 175 [2540] 225 [3262]	Cont Int ⁽¹⁾	103 [75.9] 126 [92.8]	Cont Int ⁽¹⁾	40 [10.6] 50 [13.2]	Cont Int ⁽¹⁾	775 969	Cont Int ⁽¹⁾	6.8 [9.1] 8.4 [11.2]
BRZ 65	64.9 [3.95]	Cont Int ⁽¹⁾ Peak ⁽²⁾	175 [2537] 200 [2900] 225 [3262]	Cont Int ⁽¹⁾ Peak ⁽²⁾	150 [2175] 185 [2682] 225 [3262]	Cont Int ⁽¹⁾	140 [103.1] 166 [122.3]	Cont Int ⁽¹⁾	50 [13.2] 60 [15.9]	Cont Int ⁽¹⁾	770 924	Cont Int ⁽¹⁾	9.2 [12.3] 10.6 [14.2]
BRZ 80	80.4 [4.9]	Cont Int ⁽¹⁾ Peak ⁽²⁾	175 [2537] 200 [2900] 225 [3262]	Cont Int ⁽¹⁾ Peak ⁽²⁾	175 [2537] 200 [2900] 225 [3262]	Cont Int ⁽¹⁾	197 [145.1] 218 [160.6]	Cont Int ⁽¹⁾	60 [15.9] 75 [19.8]	Cont Int ⁽¹⁾	746 933	Cont Int ⁽¹⁾	13 [17.4] 15 [20.1]
BRZ 100	100 [6.1]	Cont Int ⁽¹⁾ Peak ⁽²⁾	175 [2537] 200 [2900] 225 [3262]	Cont Int ⁽¹⁾ Peak ⁽²⁾	175 [2537] 200 [2900] 225 [3262]	Cont Int ⁽¹⁾	237 [174.6] 277 [204.1]	Cont Int ⁽¹⁾	60 [15.9] 75 [19.8]	Cont Int ⁽¹⁾	600 750	Cont Int ⁽¹⁾	13 [17.4] 15 [20.1]
BRZ 130	125.7 [7.66]	Cont Int ⁽¹⁾ Peak ⁽²⁾	175 [2537] 200 [2900] 225 [3262]	Cont Int ⁽¹⁾ Peak ⁽²⁾	175 [2537] 200 [2900] 225 [3262]	Cont Int ⁽¹⁾	300 [221.1] 340 [250.5]	Cont Int ⁽¹⁾	60 [15.9] 75 [19.8]	Cont Int ⁽¹⁾	477 597	Cont Int ⁽¹⁾	12.5 [16.8] 14.5 [19.4]
BRZ 160	160 [9.76]	Cont Int ⁽¹⁾ Peak ⁽²⁾	175 [2537] 200 [2900] 225 [3262]	Cont Int ⁽¹⁾ Peak ⁽²⁾	140 [2030] 175 [2540] 225 [3262]	Cont Int ⁽¹⁾	296 [218.1] 375 [276.3]	Cont Int ⁽¹⁾	60 [15.9] 75 [19.8]	Cont Int ⁽¹⁾	375 469	Cont Int ⁽¹⁾	10 [13.4] 12.5 [16.8]
BRZ 200	200 [12.2]	Cont Int ⁽¹⁾ Peak ⁽²⁾	175 [2537] 200 [2900] 225 [3262]	Cont Int ⁽¹⁾ Peak ⁽²⁾	115 [1667] 140 [2030] 225 [3262]	Cont Int ⁽¹⁾	297 [218.8] 380 [280]	Cont Int ⁽¹⁾	60 [15.9] 75 [19.8]	Cont Int ⁽¹⁾	300 375	Cont Int ⁽¹⁾	8.5 [11] 10 [13.4]
BRZ 250	250 [15.2]	Cont Int ⁽¹⁾ Peak ⁽²⁾	175 [2537] 200 [2900] 225 [3262]	Cont Int ⁽¹⁾ Peak ⁽²⁾	90 [1305] 120 [1740] 225 [3262]	Cont Int ⁽¹⁾	297 [218.8] 377 [277.8]	Cont Int ⁽¹⁾	60 [15.9] 75 [19.8]	Cont Int ⁽¹⁾	240 300	Cont Int ⁽¹⁾	7.1 [9.5] 8.5 [11]
BRZ 315	314.5 [19.1]	Cont Int ⁽¹⁾ Peak ⁽²⁾	175 [2537] 200 [2900] 225 [3262]	Cont Int ⁽¹⁾ Peak ⁽²⁾	70 [1020] 100 [1450] 210 [3045]	Cont Int ⁽¹⁾	300 [221.1] 420 [309.5]	Cont Int ⁽¹⁾	60 [15.9] 75 [19.8]	Cont Int ⁽¹⁾	191 238	Cont Int ⁽¹⁾	5 [6.7] 6.6 [8.8]
BRZ 400	393 [23.9]	Cont Int ⁽¹⁾ Peak ⁽²⁾	175 [2537] 200 [2900] 225 [3262]	Cont Int ⁽¹⁾ Peak ⁽²⁾	55 [800] 85 [1230] 175 [2537]	Cont Int ⁽¹⁾	292 [215.2] 425 [313.2]	Cont Int ⁽¹⁾	60 [15.9] 75 [19.8]	Cont Int ⁽¹⁾	153 191	Cont Int ⁽¹⁾	4.1 [5.4] 6.1 [8.1]

Motore Motor	Max press. di scarico con drenaggio aperto Max back pressure with drain line bar [psi]		Pressione max avviamento a vuoto Max starting pressure in unloaded conditions bar [psi]		Coppia min di spunto Min starting torque Nm [lbf-ft]	
	Cont Int ⁽¹⁾ Peak ⁽²⁾	175 [2538] 200 [2900] 225 [3263]	Cont Int ⁽¹⁾ Peak ⁽²⁾	10 [145]	Cont Int ⁽¹⁾	75[55.3] 95[70.0]
BRZ 50	Cont Int ⁽¹⁾ Peak ⁽²⁾	175 [2538] 200 [2900] 225 [3263]	Cont Int ⁽¹⁾ Peak ⁽²⁾	10 [145]	Cont Int ⁽¹⁾	75[55.3] 95[70.0]
BRZ 65	Cont Int ⁽¹⁾ Peak ⁽²⁾	175 [2538] 200 [2900] 225 [3263]	Cont Int ⁽¹⁾ Peak ⁽²⁾	10 [145]	Cont Int ⁽¹⁾	120[88.4] 140[103.1]
BRZ 80	Cont Int ⁽¹⁾ Peak ⁽²⁾	175 [2538] 200 [2900] 225 [3263]	Cont Int ⁽¹⁾ Peak ⁽²⁾	10 [145]	Cont Int ⁽¹⁾	160[118] 180[133]
BRZ 100	Cont Int ⁽¹⁾ Peak ⁽²⁾	175 [2538] 200 [2900] 225 [3263]	Cont Int ⁽¹⁾ Peak ⁽²⁾	10 [145]	Cont Int ⁽¹⁾	200[147] 225[166]
BRZ 130	Cont Int ⁽¹⁾ Peak ⁽²⁾	175 [2538] 200 [2900] 225 [3263]	Cont Int ⁽¹⁾ Peak ⁽²⁾	9 [131]	Cont Int ⁽¹⁾	255[188] 290[214]
BRZ 160	Cont Int ⁽¹⁾ Peak ⁽²⁾	175 [2538] 200 [2900] 225 [3263]	Cont Int ⁽¹⁾ Peak ⁽²⁾	7 [102]	Cont Int ⁽¹⁾	250[184] 300[221]
BRZ 200	Cont Int ⁽¹⁾ Peak ⁽²⁾	175 [2538] 200 [2900] 225 [3263]	Cont Int ⁽¹⁾ Peak ⁽²⁾	5 [72.5]	Cont Int ⁽¹⁾	250[184] 320[236]
BRZ 250	Cont Int ⁽¹⁾ Peak ⁽²⁾	175 [2538] 200 [2900] 225 [3263]	Cont Int ⁽¹⁾ Peak ⁽²⁾	5 [72.5]	Cont Int ⁽¹⁾	250[184] 310[228]
BRZ 315	Cont Int ⁽¹⁾ Peak ⁽²⁾	175 [2538] 200 [2900] 225 [3263]	Cont Int ⁽¹⁾ Peak ⁽²⁾	5 [72.5]	Cont Int ⁽¹⁾	250[184] 300[221]
BRZ 400	Cont Int ⁽¹⁾ Peak ⁽²⁾	175 [2538] 200 [2900] 225 [3263]	Cont Int ⁽¹⁾ Peak ⁽²⁾	5 [72.5]	Cont Int ⁽¹⁾	250[184] 320[236]

* Le condizioni intermittenti non devono durare più del 10% di ogni minuto. Intermittent duty must not exceed 10% each minute.

** Le condizioni di picco non devono durare più del 1% di ogni minuto. Peak duty must not exceed 1% each minute.

Per le caratteristiche tecniche non elencate fare riferimento alla parte del catalogo relativa ai motori BR.

As regards not specified technical features, please refer to the section of the catalogue that concerns BR motors.

SPECIALE A RICHIESTA - SPECIAL ON REQUEST

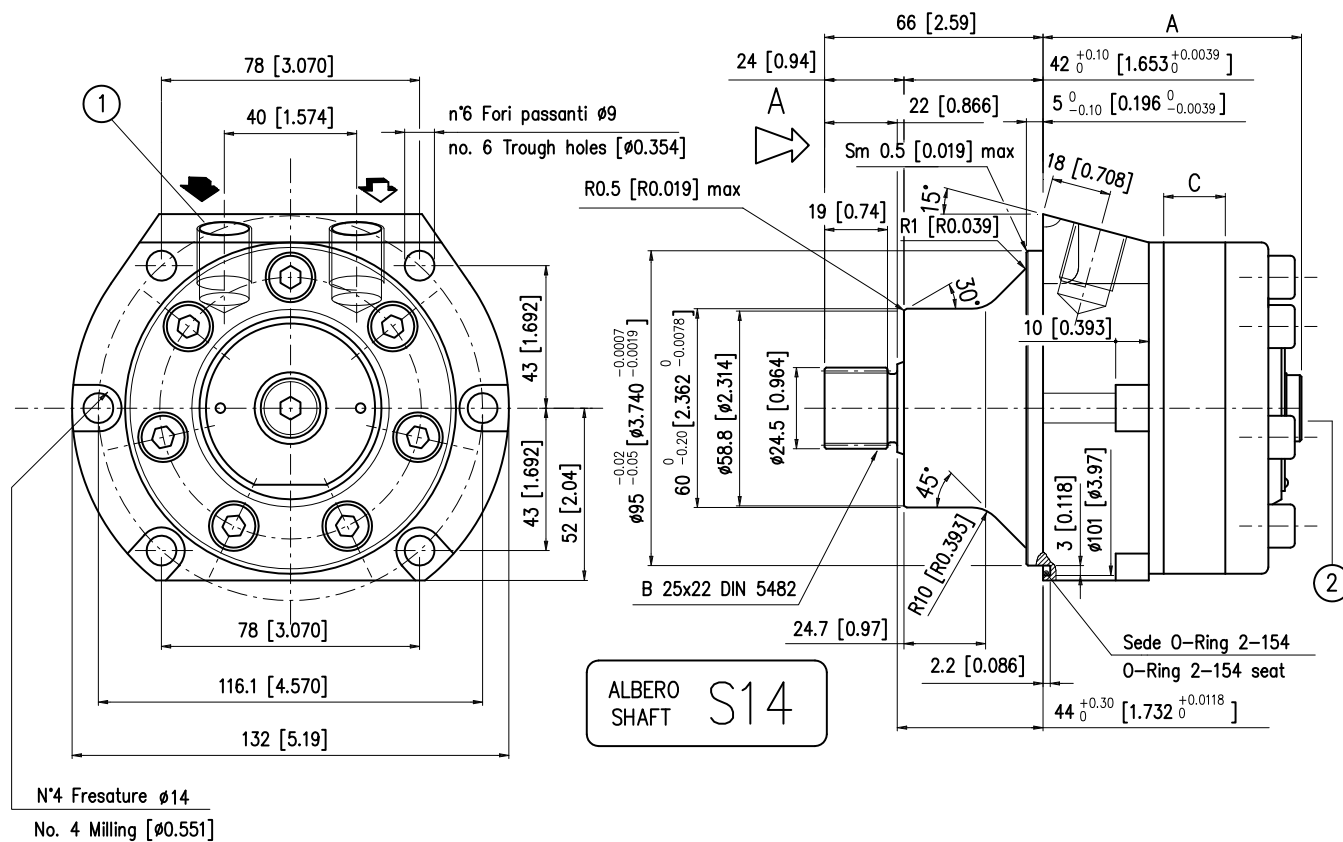

- 1) N° 2 fori di alimentazione 3/8 G (BSPP) profondità filetto 17 mm
No. 2 3/8 G (BSPP) main ports thread depth 0.66 in.
- 2) Drenaggio motore 1/4 G (BSPP) profondità filetto 15 mm Max
1/4 G (BSPP) motor drain thread depth 0.59 in Max

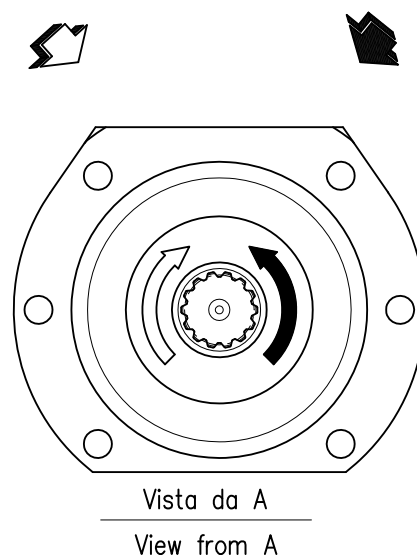

		BRZL 50	BRZL 65	BRZL 80	BRZL 100	BRZL 130	BRZL 160	BRZL 200	BRZL 250	BRZL 315	BRZL 400
A	mm [in]	67.5 [2.65]	69.8 [2.74]	72.5 [2.85]	75.9 [2.98]	80.3 [3.16]	86.3 [3.39]	93.3 [3.67]	102 [4.01]	113.3 [4.46]	126.9 [4.99]
C	mm [in]	9 [0.354]	11.3 [0.444]	14 [0.551]	17.4 [0.68]	21.8 [0.85]	27.8 [1.09]	34.8 [1.37]	43.5 [1.71]	54.8 [2.15]	68.38 [2.69]
Peso Weight	kg [lb]	5.6 [12.3]	5.8 [12.7]	5.9 [13.0]	6.2 [13.7]	6.5 [14.3]	6.8 [15.0]	7.1 [15.6]	7.6 [16.8]	8.3 [18.3]	9.5 [20.9]

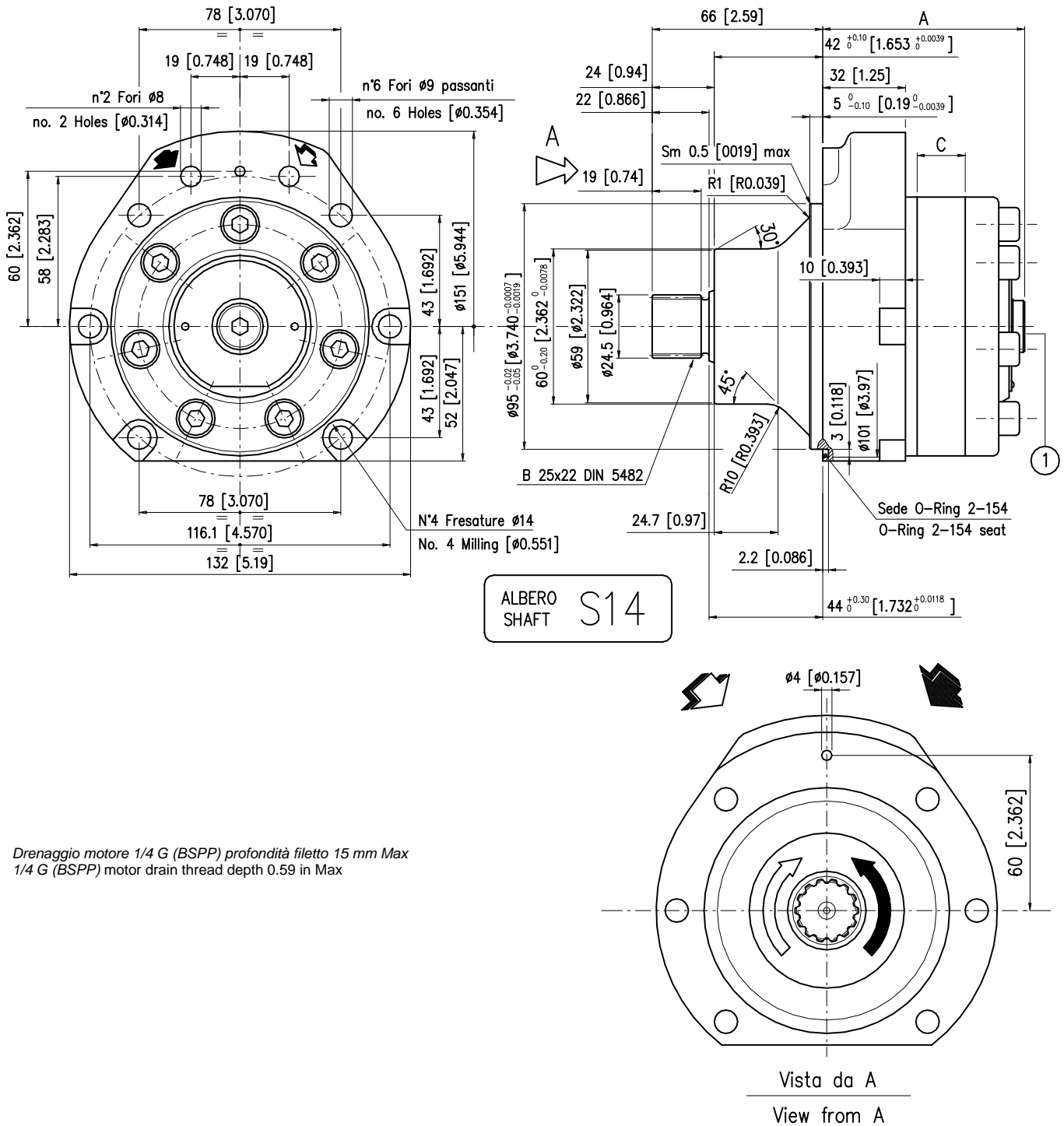

1) Drenaggio motore 1/4 G (BSPP) profondità filetto 15 mm Max
1/4 G (BSPP) motor drain thread depth 0.59 in Max

Per l'alimentazione del motore sono disponibili le due valvole VCT11-SF e VCT11-AF ed il collettore modulare CMZ-SF e CMZ-AF. VCT11-SF and VCT11-AF valves and CMZ-SF and CMZ-AF manifold are available to allow motor connection.

		BRZV 50	BRZV 65	BRZV 80	BRZV 100	BRZV 130	BRZV 160	BRZV 200	BRZV 250	BRZV 315	BRZV 400
A	mm [in]	67.5 [2.65]	69.8 [2.74]	72.5 [2.85]	75.9 [2.98]	80.3 [3.16]	86.3 [3.39]	93.3 [3.67]	102 [4.01]	113.3 [4.46]	126.9 [4.99]
C	mm [in]	9 [0.354]	11.3 [0.444]	14 [0.551]	17.4 [0.68]	21.8 [0.85]	27.8 [1.09]	34.8 [1.37]	43.5 [1.71]	54.8 [2.15]	68.38 [2.69]
Peso Weight	kg [lb]	5.6 [12.3]	5.8 [12.7]	5.9 [13.0]	6.2 [13.7]	6.5 [14.3]	6.8 [15.0]	7.1 [15.6]	7.6 [16.8]	8.3 [18.3]	9.5 [20.9]

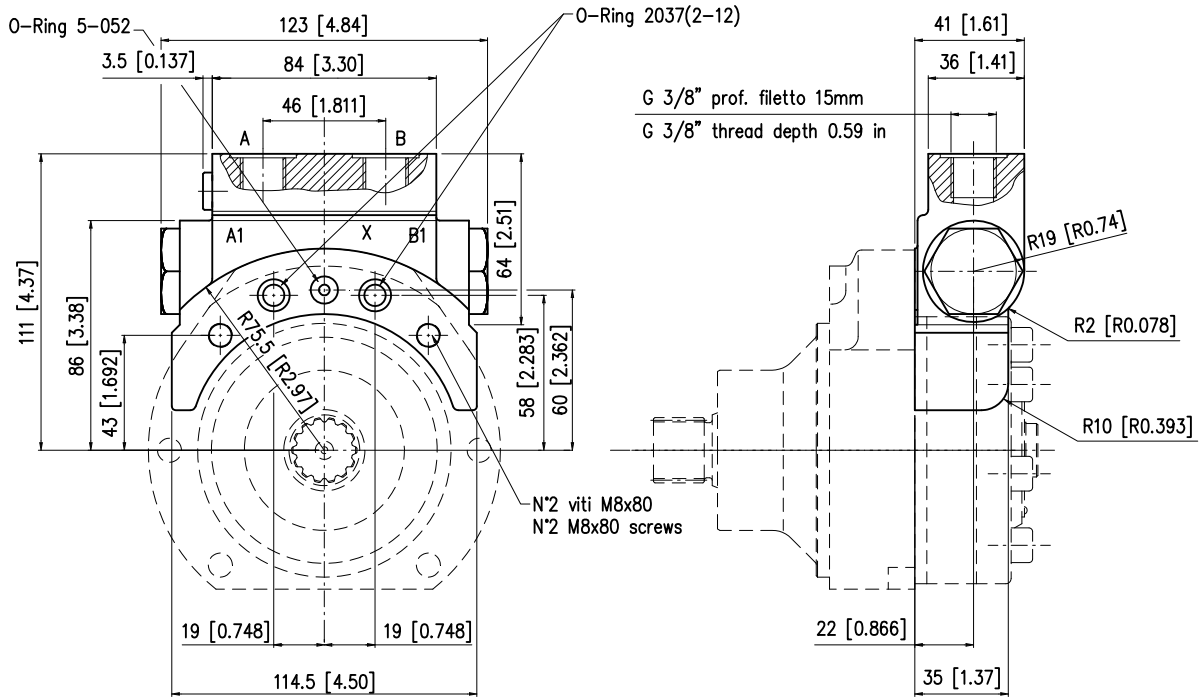

VERSIONE METRICA
METRIC VERSION

VERSIONE SAE
SAE VERSION

A-B = 3/8 G (BSPP) prof. filetto 15mm
3/8 G (BSPP) thread depth [0.59 in]

A-B = 3/4-16 UNF prof. filetto 15mm
3/4-16 UNF thread depth [0.59 in]

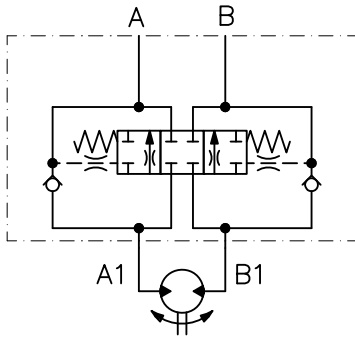

VCT 11 - SF

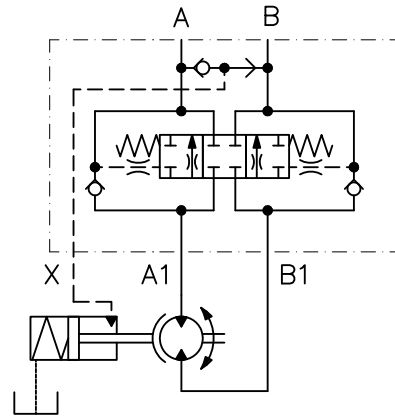

VCT 11 - AF

Peso - Weight (kg [lb])	1.8 [3.97]
--------------------------------	-------------------

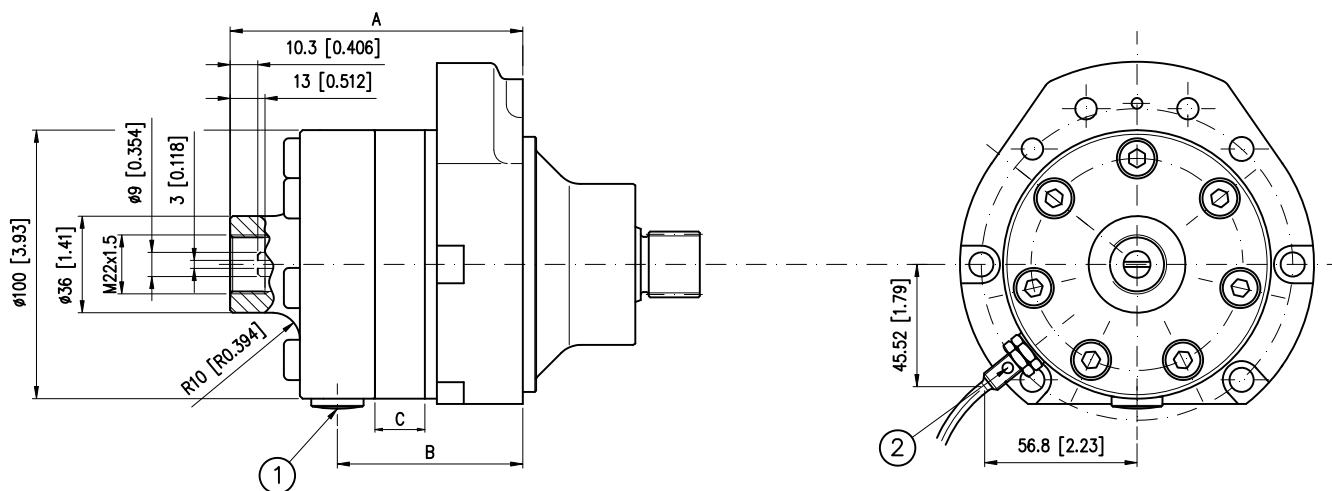

1) Drenaggio motore 1/4 G (BSPP) profondità 12 mm
1/4 G (BSPP) drain port thread depth 0.472 in

2) Attacco sensore M8x1
Sensor connection M8x1

ATTENZIONE:

- L'alberino contagiri ha velocità pari a 6 volte quella dell'albero primario del motore e senso di rotazione opposto.
- N.B.: Non sono accettati carichi assiali o radiali sull'albero contagiri. Coppia massima trasmissibile 1 Nm.
- Il motore viene fornito senza il sensore elettronico: se necessario, richiederlo in fase di ordinazione.
- Pressione massima ammessa sulla guarnizione dell'albero contagiri con drenaggio chiuso: 25 bar.

WARNING:

- Tacho shaft has a 6 times higher revolution speed than the motor shaft and opposite direction of rotation.
- NOTE: Axial or radial load on tacho shaft must be avoided. Max torque on tacho 1 Nm [0.737 lbf-ft].
- The electronic sensor is not supplied: if required, please state it clearly on order form.
- Max pressure admissible on the shaft seal with closed drain port 25 bar [362 psi].

		BRZV 50	BRZV 65	BRZV 80	BRZV 100	BRZV 130	BRZV 160	BRZV 200	BRZV 250	BRZV 315	BRZV 400
A	mm [in]	100 [3.93]	102.3 [4.02]	105 [4.13]	108.4 [4.26]	112.8 [4.44]	118.8 [4.67]	125.8 [4.95]	134.5 [5.29]	145.8 [5.74]	159.4 [6.27]
B	mm [in]	60.4 [2.37]	62.7 [2.46]	65.4 [2.57]	68.8 [2.70]	73.2 [2.88]	79.2 [3.11]	86.2 [3.39]	94.9 [3.73]	106.2 [4.18]	119.8 [4.71]
C	mm [in]	9 [0.354]	11.3 [0.444]	14 [0.551]	17.4 [0.68]	21.8 [0.85]	27.8 [1.09]	34.8 [1.37]	43.5 [1.71]	54.8 [2.15]	68.38 [2.69]
Peso Weight	kg [lb]	6.1 [13.4]	6.3 [13.8]	6.4 [14.1]	6.7 [14.8]	7.0 [15.4]	7.3 [16.1]	7.6 [16.8]	8.1 [17.9]	8.8 [19.4]	9.5 [20.9]

CARATTERISTICHE TECNICHE DEL SENSORE ELETTRONICO
ELECTRONIC SENSOR TECHNICAL FEATURES

Segnale in uscita versione elettronica
Output signal electronic tacho

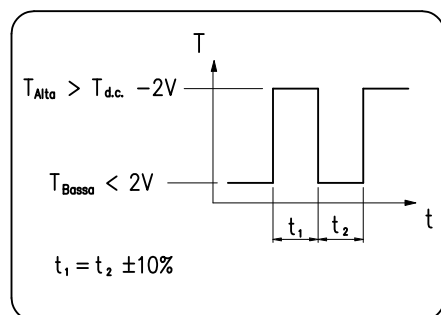

Numero d'impulsi per giro = 90
Principio di funzionamento induttivo
Funzione di uscita PNP
Tensione nominale 10-65 V d.c.
Caricabilità massima 300 mA
Frequenza massima 10000 Hz
Campo di temperatura -25C +85C
Grado di protezione IP 67

Versioni disponibili:

- Sensore con cavo a tre fili lunghezza 2 metri (cod.424.0050.0000)
- Sensore con attacco per connettore tipo binder (cod.424.0060.0000) + connettore tipo binder
- con cavo a tre fili lunghezza 5 metri (cod.424.0080.0000)

Number of pulses per revolution = 90
Inductive principle
Output current PNP
Voltage 10-65 V d.c.
Max load 300 mA
Max frequency 10000 Hz
Temperature range -25C +85C
Enclosure IP 67

Available versions:

- Sensor with 2 metres three wires cable (cod.424.0050.0000)
- Sensor with binder plug connection (cod.424.0060.0000) + binder connecting
- plug with 5 metres three wires cable (cod.424.0080.0000)

Collettore modulare CMZ senza sblocco freno (SF)
Manifold CMZ without brake opening port (SF)

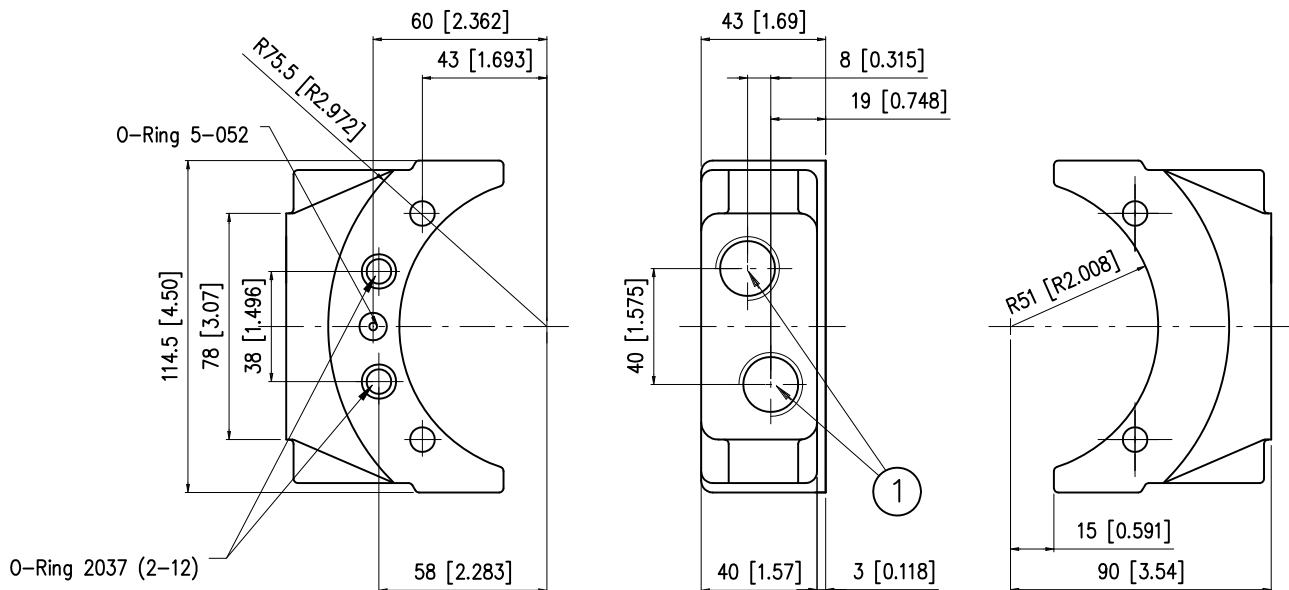

- 1) N° 2 Fori d'alimentazione 1/2 G (BSPP) Prof.fil. 19 mm
N°2 1/2 G (BSPP) main ports thread depth 0.74 in

Collettore modulare CMZ con sblocco freno (AF)
Manifold CMZ with brake opening port (AF)

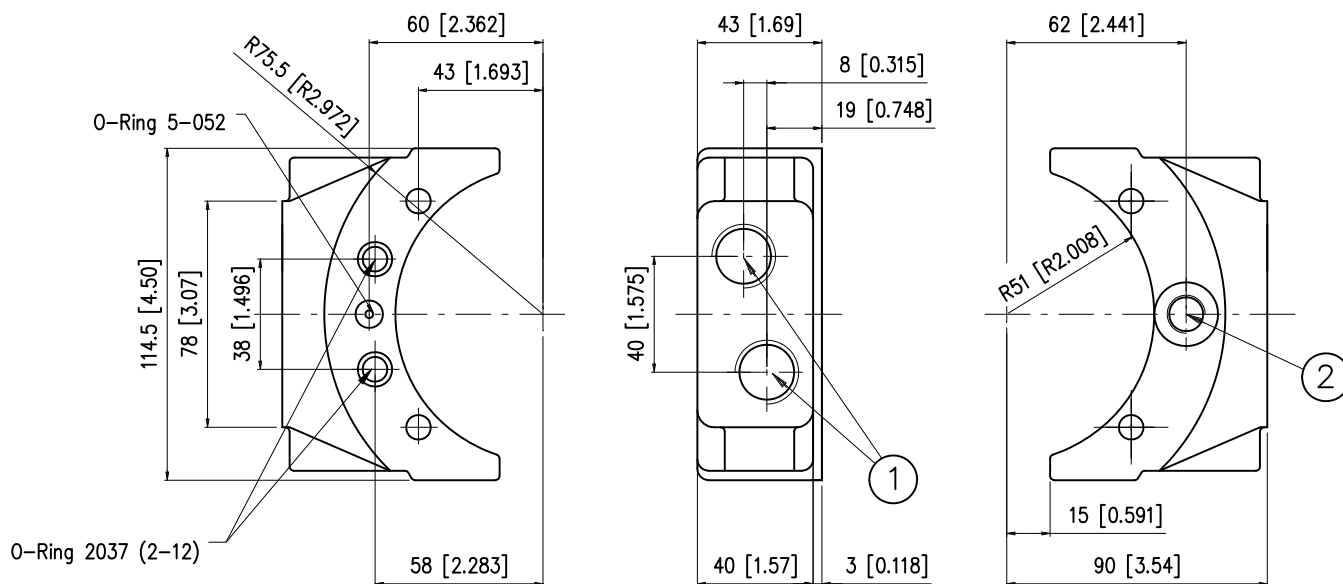

- 1) N° 2 Fori d'alimentazione 1/2 G (BSPP) Prof.fil. 19 mm
N°2 1/2 G (BSPP) main ports thread depth 0.74 in
2) Apertura freno 1/4 G (BSPP) Prof.fil. 13 mm
1/4 G (BSPP) drain port thread depth 0.511 in

MASSIMA PRESSIONE AMMESSA SULLA GUARNIZIONE ALBERO MAX PERMISSIBLE SHAFT PRESSURE

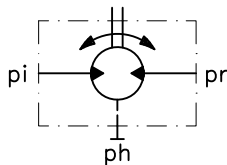
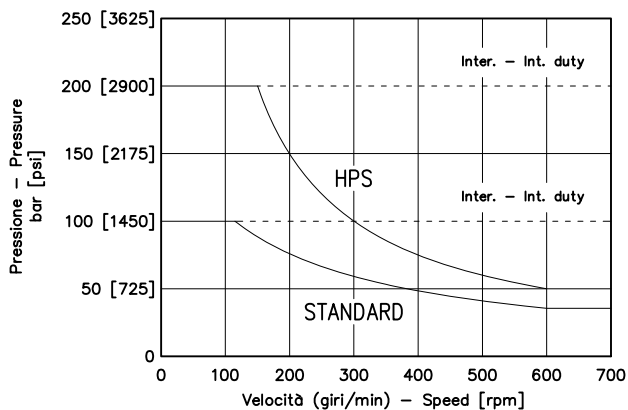

I motori BRZ sono forniti nella versione con guarnizioni standard (curva STANDARD) o nella versione con guarnizioni ad alta pressione (curva HPS). Nei motori BRZ non sono presenti le valvole interne di drenaggio. La pressione sulla guarnizione (ph) è la media tra le pressioni di alimentazione e di scarico del motore. Se ph supera il valore massimo ammesso (vedi grafico a fianco) occorre aprire il drenaggio.

N.B.: Sulla versione TAC/U non è possibile installare guarnizioni HPS.

Motors are supplied in standard seal version (STANDARD curve) or in HPS seal version (HPS curve) BRZ motors don't feature build-in check valves. The (ph) pressure on the seal is the average between inlet and outlet pressure. If ph exceeds rated figures (see graph on side), the drain line must be connected.

N.B.: TAC/U version is not available with HPS seals.

$$Ph = \frac{pi + pr}{2} [bar]$$

ph = pressione in carcassa

pi = pressione di alimentazione

pr = pressione di scarico

ph = housing pressure

pi = inlet. pressure

pr = outlet pressure

Informazioni sul prodotto

Dati i continui sviluppi, le modifiche e le migliorie al prodotto, la S.A.M. Hydraulik Spa non sarà responsabile per eventuali informazioni che possano indurre in errore, od erronee, riportate da cataloghi, istruzioni, disegni, dati tecnici e altri dati forniti dalla S.A.M. Hydraulik Spa. Non sarà possibile basare alcun procedimento legale su tale materiale.

Modifiche del prodotto. La S.A.M. Hydraulik Spa si riserva il diritto di variare i suoi prodotti, anche quelli già ordinati, senza notifica.

Notice

Due to the continuous product developments, modifications and improvements S.A.M. Hydraulik Spa will not be held responsible for any erroneous information or data that may lead to errors, indicated in catalogues, instructions, drawings, technical data and other data supplied by S.A.M. Hydraulik Spa. Therefore, legal actions cannot be based on such material. **Product development.** S.A.M. Hydraulik Spa reserves the right to make changes to its products, even for those already ordered, without notice.
